



## **BID PACKET**

**Butte County Resource Conservation District  
(BCRCD)**

**Coutelenc Rd. MacNab Fencing Project**

**Bids Due on or Before**

**5:00 PM PST**

**May 7, 2026**

## Contents

<b>SECTION 1 - NOTICE TO CONTRACTORS</b> .....	3
<b>SECTION 2 - PROJECT DESCRIPTION</b> .....	5
<b>SECTION 3 - CONSTRUCTION SPECIFICATIONS</b> .....	7
<b>SECTION 4 - BIDDING REQUIREMENTS SUMMARY</b> .....	10
<b>SECTION 5 - INSTRUCTIONS TO BIDDERS</b> .....	11
<b>SECTION 6: BID PROPOSAL FORM</b> .....	19
<b>SECTION 7: NON-COLLUSION AFFIDAVIT</b> .....	26
<b>SECTION 8: FIRE PLAN REVIEW AND ACKNOWLEDGEMENT</b> .....	27
<b>SECTION 9 - PERFORMANCE BOND</b> .....	28
<b>SECTION 10 - CONTRACT AGREEMENT</b> .....	30
<b>SECTION 11 - GENERAL CONDITIONS</b> .....	37
<b>Appendix A – State Prevailing Wage determination</b> .....	78
<b>Appendix B - SITE MAP</b> .....	88
<b>Appendix C – FIRE PLAN</b> .....	89

## SECTION 1 - NOTICE TO CONTRACTORS

Butte County Resource Conservation District (BCRCD) is seeking bids from qualified contractors for an upcoming fencing project, the **Coutelenc Rd MacNab Fencing Project**.

The proposed project includes installing approximately 1,800 ft of heavy-duty pipe or pipe-and-rock fence (see example images below). The project is adjacent to Coutelenc Rd, starting a few dozen feet north of the intersection of Coutelenc Road and Skyway (see map). The project site is owned by the U.S. Forest Service (APN = 058-130-004). The soil and rock at the work site contain naturally occurring asbestos; Contractor will be responsible for complying with all applicable laws and regulations (see Section 3 below). The Contractor is responsible for all the prescribed work, materials, and associated equipment necessary to complete the project.

The bid package and other contract documents relating to the project may be viewed beginning March 31 online at <https://www.bcrccd.org/announcements>. There will be a **pre-bid mandatory meeting** at the site on Tuesday, April 21, 2026 at 9:00 pm. A certified asbestos consultant will be on hand to answer questions and offer guidance during this pre-bid site walk.

Contractor should mail, hand deliver, or email (PDF) their sealed proposal below by May 7, 2026 at 5:00 pm at which time all bids received will be publicly opened and read aloud outside of the BCRCD office. Electronic submissions preferred.

**Butte County Resource Conservation District**  
**641 Entler Ave. Suite 47**  
**Chico CA. 95928.**  
**Or**  
**[wolfy@bcrccd.org](mailto:wolfy@bcrccd.org)**

At their soonest meeting thereafter (likely May 21), the BCRCD Board of Directors will review bids and strongly consider Award to BCRCD's recommendation of most qualified contractor, which will be based on contractor's bid, experience, and the project's available funding. The BCRCD may issue a Notice to Award within one to sixty (60) business days of the Board of Directors' meeting, based on their decision.

BCRCD reserves the right to accept the bid which is in the best interest of BCRCD even if it is not the lowest bid. BCRCD has the right to waive irregularities in any bid, or to reject any and all bid proposals. Any bid protests shall be submitted to BCRCD no later than 5:00 PM PST on the fifth (5th) business day after the date that the bids are opened. Bid protests must be in writing and must set forth, in detail, the factual and legal basis for the protest.

The project is located on Forest Service land (Plumas National Forest, Feather River Ranger District) and the contractor must comply with all applicable laws and requirements necessary to

perform work on Federal land. The Contractor must have an active California Contractors license and must comply with all applicable State of California contracting laws, including licenses, bond, and liability insurance. See Section 4 for license requirements and section 11, article 5, for liability insurance requirements.

The scope of this project falls within the category of public works project for Federal and State requirements, and as such, the contractor shall abide by all applicable Federal and State laws for the payment of prevailing wages and certified payroll.

Contractor and any subcontractor(s) agree to furnish Certified Payroll Affidavits, Statements of Non-Performance, completed and processed DAS 140 & 142 forms and all other California Labor Compliance documents. (DAS 140 must be filed before the contractor is on the Job site.) All training fund contribution certifications submitted to the contractor must include a copy of the check sent to that institution. All certified payroll documents or non-performance documents with original signatures and payroll numbers must be submitted biweekly to Butte County Resource Conservation District and uploaded to DIR, <https://efiling.dir.ca.gov/eCPR/pages/eCPROnlineForm.jsp> Include DIR payroll submission confirmation sheets with weekly payroll reports.

Contractor must contact USA California to mark any underground utilities in the project work area at least three (3) days prior but no more than fourteen (14) days prior to the Work.

The awarded contractor shall furnish a performance bond within fifteen (15) calendar days of receipt of the Notice of Award in an amount equal to at least 100% of the contract price. See Section 10 for more details.

At the time of the opening of bids, each bidder will be presumed to have read and be thoroughly familiar with the plans and Contract Documents (including all addenda). The failure or omission of any bidder to examine any form, instrument, or document shall in no way relieve any bidder from any obligation in respect to their bid.

**Bid Packages shall include the following originally signed documents:**

Bid Proposal Form (Section 6)

Non Collusion Affidavit (Section 7)

Bidder Verification of Site Visit (Section 8)

Fire Plan

For any questions regarding the Construction Specifications, contact the Project Manager, Wolfy Rougle, at [wolfy@bcrd.org](mailto:wolfy@bcrd.org) or (530) 721-0164.

**END OF SECTION**

## **SECTION 2 - PROJECT DESCRIPTION**

The project involves installing approximately 1,800 linear feet of permanent fencing. The fencing should consist of pipe, rock, or (most likely) a hybrid of the two. One pedestrian entrance shall be built into the fence (see illustration near end of this section). Contractors are asked to provide a technical approach and explain how they would combine the elements of pipe and rock to create a permanent, heavy-duty, aesthetically appealing fence that blends into the unique site.

The fence is in two segments, both of which will connect to an existing heavy metal gate on the property. The project also involves the installation of up to 48 existing “no vehicles” signs (which will be furnished by BCRCD).

See Site Map in Appendix B of this Bid Packet.

The Contractor is responsible for all the prescribed work, materials, and associated equipment necessary to complete the project.

The site contains naturally occurring asbestos; see Section 3 below.

The work herein described will fall into the category of public works project for Federal and State requirements. The Contractor certifies that it is aware of and shall abide by all applicable Federal and State laws concerning the payment of prevailing wages.

Contractor must contact USA California to mark any underground utilities in the project work area at least three (3) days prior but no more than fourteen (14) days prior to the Work.

The selected contractor will conduct a second site walk with BCRCD representatives or designee at the project’s beginning to ensure the routing and other design and construction elements are fully understood. The Contractor will be provided with a GIS shapefile and/ or GPS track of the project areas. The Contractor will need to work with BCRCD representatives and Forest Service on the project sequence to align with detections of nesting birds, archeological monitoring, and (especially) rare plants.

**Sample images of some possible technical approaches**

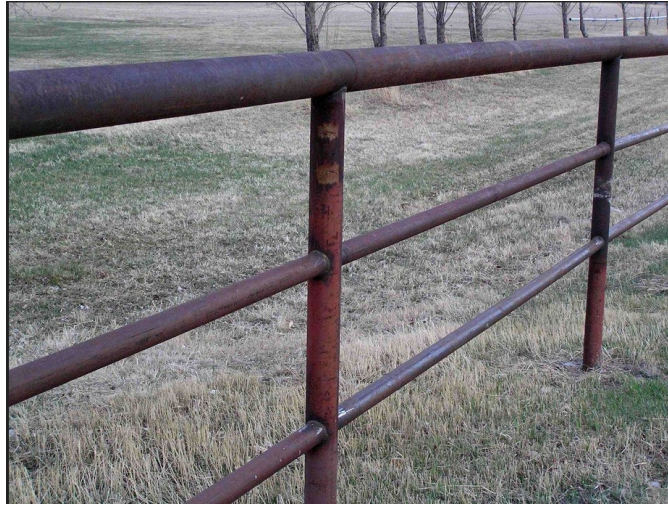

**END OF SECTION**

MATERIAL LIST

ITEM NO.	PART OR ASSEMBLY NOMENCLATURE	NO. REQ'D.	MATERIAL OR DESCRIPTION	SHT
1	POST	3	10" DIA. CCA TREATED POST 6' LONG	
2	PIPE RAIL	AR	4-7/16" GALV. STEEL PIPE (4" ID)	
3	ANCHORS	9	STEEL ROD, 5/8" DIA x 16" LG	
4	FOOTINGS	3	MIXED CONCRETE BAGS X 100 #	

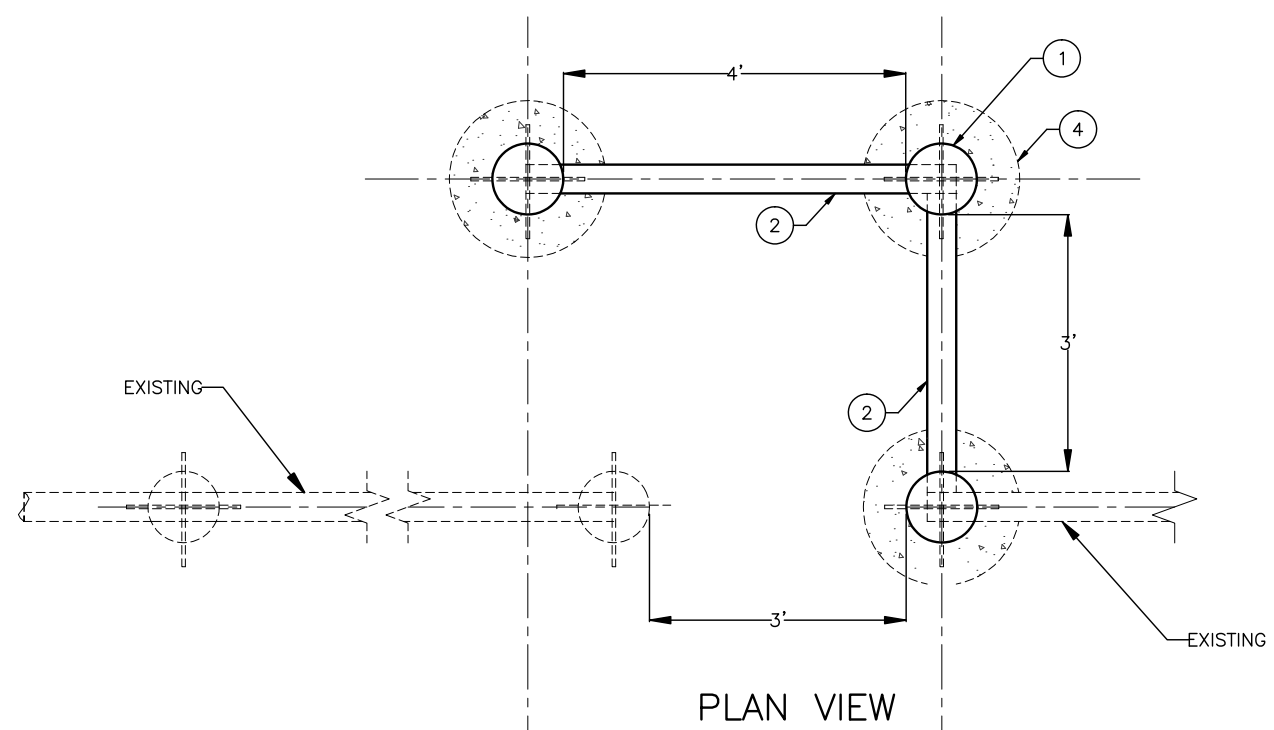

PLAN VIEW

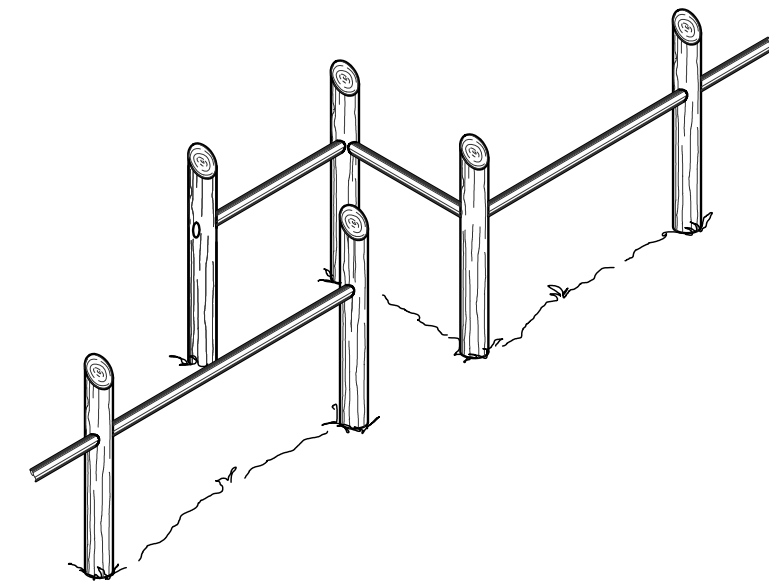

ISOMETRIC VIEW

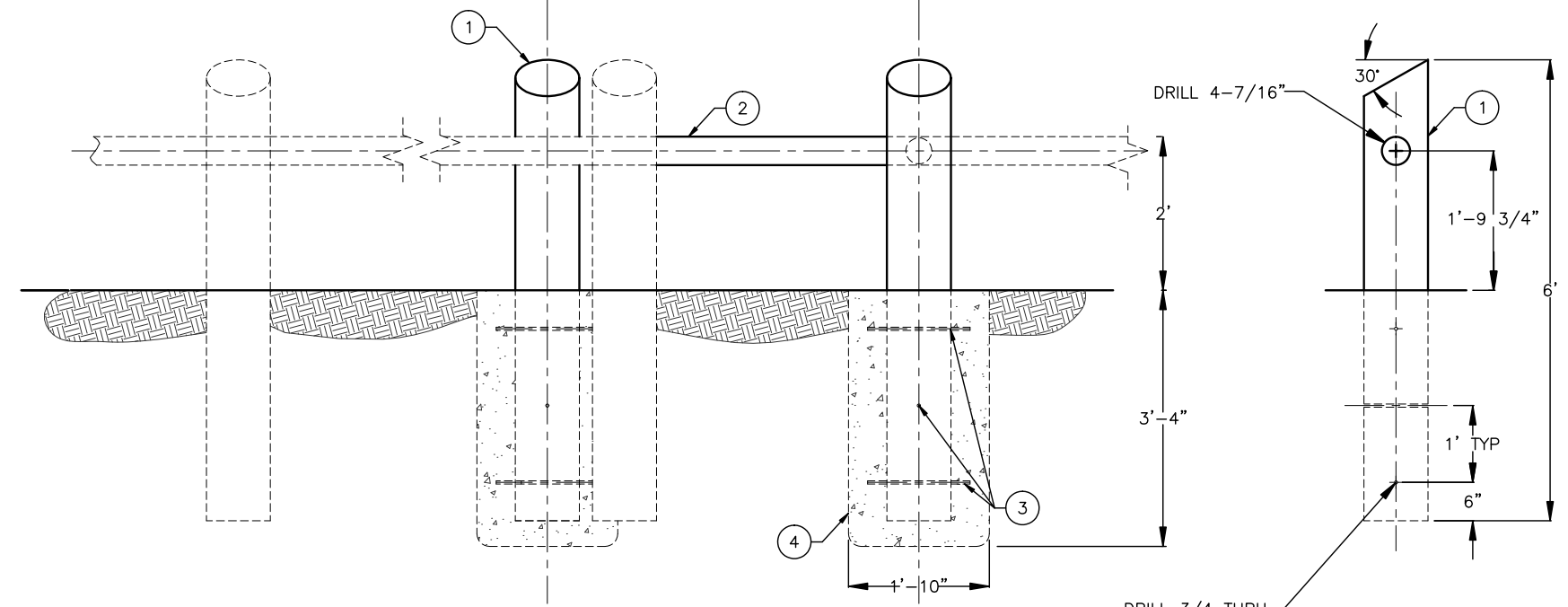

ELEVATION VIEW

NOTES:

1. SALVAGED WELL CASING MAY BE USED IN PLACE OF GALVANIZED PIPE RAILS. (SHOWN IN THE DRAWING). ADJUST THE HOLE IN THE POSTS TO 3 7/8" DIAMETER IF WELL CASING IS USED. AN OUTFITTING COMPANY MAY HAVE INFORMATION ON SALVAGED PIPE.
2. PIPE JOINTS TO BE 20' IN LENGTH AND JOINED BY WELDING TO CREATE A CONTINUOUS RUN THROUGH POSTS.
3. ON THE END RAILS, RAILS SHOULD END IN THE CENTER OF THE POST.
4. THE 4' RAIL SECTION IS NECESSARY TO HELP BLOCK MOTORCYCLE ENTRY.

<p><b>GENERAL NOTES</b></p> <p>1. UNLESS OTHERWISE SPECIFIED TOLERANCES ON DIMENSIONS ARE TO BE AS FOLLOWS: DECIMAL ± .010 FRACTIONAL ± 1/16 ANGLES ± 1/2</p> <p>2. REMOVE ALL BURRS AND SHARP CORNERS.</p> <p>3. DO NOT SCALE DRAWING.</p> <p>4. MAKE NO SUBSTITUTION OF MATERIALS OR ALTERATION OF DIMENSIONS WITHOUT PRIOR WRITTEN APPROVAL BY THE TECHNOLOGY AND DEVELOPMENT CENTER.</p>	<p>U.S. DEPARTMENT OF AGRICULTURE FOREST SERVICE TECHNOLOGY &amp; DEVELOPMENT CENTER SAN DIMAS, CALIFORNIA 91773</p>
	<p>KISATCHIE NATIONAL FOREST EVANGELINE RANGER DISTRICT LORAN SITE TRAFFIC CONTROL BARRIER</p>
<p>DRAWN BY M.M.Demole CHKD. BY E.J. DATR. 9-9-05 REVIEWED BY ELLEN EUBANKS DATE 9-9-05 APPROVED D. Meadows DATE 9-9-05 SCALE Full DATE 9-9-05</p>	<p>DWG NUMBER REC49-01 REV 0 SHEET 1 OF 1</p>

REV	ZONE	DESCRIPTION	DATE	BY	CHK

## SECTION 3 - CONSTRUCTION SPECIFICATIONS

### General Requirements

The contractor shall provide and install materials within the specifications outlined. Any deviation from the Materials Specifications must be approved by the project manager. All materials must be verified by the project manager prior to installation.

The work herein described will fall into the category of public works projects for Federal and State requirements. The Contractor certifies that it is aware of and shall abide by all applicable Federal and State laws concerning the payment of prevailing wages and certified payroll, and is registered with DIR. The expected wage classification relevant to the scope of work for this project is Laborer.

Contractor must contact USA California to mark any underground utilities in the project work area at least three (3) days prior but no more than fourteen (14) days prior to the Work.

### Fencing

The contractor shall install approximately 1,800 feet of fence, as depicted in the map. It is expected that the actual distance could be 10% more or 10% less than the mapped 1,800 feet. The fence shall consist of heavy, permanent elements. Posts should be either 1) sturdy metal pipe set into the ground (whether by drilling, driving, sinking footings, or pounding), without or without concrete/cement, or 2) boulders or stone posts. Cross-members should be sturdy metal pipe or beams. A hybrid design using both stone and metal is encouraged. Cable is not acceptable. Concrete block barriers are not acceptable. One pedestrian-only (bicycle/motorcycle exclusion) entrance shall be installed. Some stone/boulders are available on site, but not necessarily enough to complete the project, depending on the selected contractor's technical approach.

### Signage

The contractor shall install up to 48 12" x 18" metal signs at designated locations on the fencing. The sign installation shall be performed in such a way that the sign is not easily removable or vulnerable to destruction.

Materials specification:

Fence: Rock and/or steel Design shall be approved by BCRCDC prior to installation.

Sign: steel, attached to gate, treated for corrosion, provided by BCRCDC.

All galvanized materials shall be compliant with the appropriate ASTM standard.

### **Special considerations for naturally occurring asbestos**

All construction, grading, excavation, trenching, drilling, or other ground-disturbing activities performed at this site shall be conducted in full compliance with all applicable federal, state, and local regulations governing Naturally Occurring Asbestos (NOA) and asbestos exposure.

At a minimum, the Contractor shall comply with the Airborne Toxic Control Measure (ATCM) for Construction, Grading, Quarrying, and Surface Mining Operations in Areas with Naturally Occurring Asbestos (Title 17 CCR §93105); the California Division of Occupational Safety and Health (Cal/OSHA) asbestos standard for construction (Title 8 CCR §1529); the federal OSHA asbestos standard for construction (29 CFR §1926.1101), as applicable; and all requirements of the Butte County Air Quality Management District (BCAQMD).

Based on consultation with BCAQMD, this project does not meet the size thresholds requiring preparation of an Asbestos Dust Mitigation Plan (ADMP). Therefore, an ADMP is not required. However, the Contractor shall comply with all applicable dust control requirements of Title 17 CCR §93105, including Section E(1), and shall provide written confirmation of that commitment prior to mobilization.

Consistent with Title 17 CCR §93105 and BCAQMD direction, the Contractor shall implement, at a minimum, the following dust control measures:

- Limit vehicle speeds on unpaved surfaces to less than 15 miles per hour.
- Apply sufficient water prior to any ground disturbance to prevent visible emissions from crossing the property boundary.
- Maintain adequate wetting during grading, excavation, drilling, or trenching activities.
- Keep soil storage piles adequately wetted, treated with approved dust suppressants, or covered when not actively worked.
- Wash down equipment prior to exiting the site onto paved public roads.
- Clean any visible track-out on paved public roads within twenty-four (24) hours using wet sweeping or HEPA-filtered vacuum methods.

The Contractor shall prevent visible emissions from crossing the property boundary at all times. Failure to maintain effective dust control shall require immediate corrective action and may result in suspension of work.

Pursuant to Title 8 CCR §1529, the Contractor shall comply with all worker protection requirements associated with asbestos-related construction activities. Respiratory protection shall be provided when employee exposures are at or above the permissible exposure limit (0.1

fibers per cubic centimeter as an 8-hour time-weighted average) or excursion limit (1.0 f/cc over 30 minutes), when required by the applicable asbestos work classification, or when a Negative Exposure Assessment (NEA) has not been established or cannot be maintained. If respirators are required, the Contractor shall implement a compliant respiratory protection program in accordance with Title 8 CCR §5144, including medical clearance, fit testing, and training. Worker training and medical surveillance shall be provided as required under Title 8 CCR §1529.

BCRCD will retain a California Certified Asbestos Consultant (CAC) to be onsite, at minimum, on the first day of ground-disturbing activities to verify implementation of required dust control measures and to conduct a Negative Exposure Assessment (NEA), as appropriate. The provision of CAC monitoring and NEA by BCRCD does not relieve the Contractor of responsibility for compliance with Title 8 CCR §1529 or any other applicable regulation.

The Contractor is solely responsible for full regulatory compliance and for implementing all required engineering controls, work practices, notifications (if required by regulation), exposure controls, and documentation. All costs associated with regulatory compliance, dust control implementation, monitoring (other than the Owner-retained CAC on Day 1), and required protective measures shall be included in the Contractor's bid.

### **Access**

The contractor may not use Coutelenc Rd to access the site, except the existing parking lot. The contractor will be given access to the gated road that descends from the parking lot toward the river. On the site itself, the contractor will be allowed to do some vegetation clearing to improve access, but only along the fence alignment. Vehicle travel over the site, except for the parking lot and the fence alignment, is not allowed. The Forest Service will specify the acceptable width of clearing and a botanical monitor may be present to minimize damage to the site's rare plants.

### **Warranty**

The contractor is required to provide a one year warranty on the workmanship for the fence. This condition applies to gradual deterioration, damage, or depreciation of the gate from normal everyday existence, distinct from sudden or malicious damage.

## **END OF SECTION**

## SECTION 4 - BIDDING REQUIREMENTS SUMMARY

(do not submit this page)

1. Project Title: Coutelenc Road MacNab Fencing Project
2. Project Location: Just off of Coutelenc Road just north of its intersection with Skyway; T23N, R04E, section 30
3. Bid Opening Date: March 31, 2026
4. Mandatory Bid Walk: April 21, 2026, 9:00 am  
(Certified Asbestos Consultant will be on hand to answer questions)
5. Questions Due: April 24, 2026 by 5:00 PM  
Questions answered: April 28, 2026 by 5:00 PM
6. Bid Closing Date: May 7, 2026 by 5:00 PM
7. Opening Sealed Bids: May 7, 2026 at 5:00 PM
8. Bid Award Date: May 21, 2026
8. Bid Place: 641 Entler Avenue, Suite 47, Chico CA. 95928  
Or  
Preferrably submitted electronically via email to [wolfy@bcrccd.org](mailto:wolfy@bcrccd.org)
9. Construction Time Period: Must be completed by July 31, 2026, unless extension agreed on
10. License Requirement: Valid California Contractors License in a Classification Relevant to the Scope of Work
11. Liquidation Damages: \$200.00 per day
12. Performance Bond: Yes - 100% of award
13. Prevailing Wage Rates: Yes
14. Bid Valid For: 60 days

**END OF SECTION**

## SECTION 5 - INSTRUCTIONS TO BIDDERS

### 1. General

- A. The prospective bidder is made aware that the Work and associated requirements for this project are defined in a series of documents collectively referred to as the Contract Documents, which consist of the completed Bid Form, these Instructions to Bidders, the Agreement to which the General Conditions are attached, the Supplementary Conditions, any Special Provisions, the Plans, and the General Requirements and Technical Specifications and any modifications of any of the foregoing in the form of addenda or otherwise effected in accordance with the terms of the contract.

### 2. Work Included - Scope of Work

- A. The project is located off of Coutelenc Road (N 39.814, W -121.577). The project site is an area of serpentine rock, which contains naturally occurring asbestos. The site is owned by the U.S. Forest Service. The area to be fenced is a rare plant hotspot. Through this project, the site will be protected from future encroachment by unauthorized off-highway vehicle use, and have site security measures installed. The work will be completed insofar as possible without causing excessive damage to the soil and plants. A botanical monitor may be on site some or all days to direct work. Contractors must comply with Title 8 CCR §1529, Title 17 CCR §93105 (“Asbestos Airborne Toxic Control Measure for Construction, Grading, Quarrying and Surface Mining Operations”), 29 CFR §1926.1101, and all other regulations as applicable (see Section 3). A Certified Asbestos Consultant will monitor at least Day 1 of work to ensure the contractor is in compliance with acceptable protocols and to conduct a Negative Exposure Assessment.
- B. The work consists of furnishing all of the prescribed work, materials (except the metal signs, which will be furnished by BCRCD), and associated equipment necessary to complete the project.
- C. The Construction Specifications and requirements are included as Section 3.
- D. The primary components of the work are generally described as follows:
  1. Construction of approximately 1,800 feet of pipe or pipe-and-rock fencing. Depending on the technical approach selected by the contractor, this will likely include the digging, driving, or drilling of up to 180-200 post holes. The contractor must have a plan in place for protecting the public and workers from exposure to the naturally occurring asbestos at the site. The nature and details of the contractor’s exposure prevention plan will

depend on the contractor's technical approach. One (1) pedestrian entrance must be installed, constructed in such a way as to exclude bicycles and motorcycles.

2. Installation of up to 48 metal signs, 12 inches by 18 inches in diameter, to be directly affixed to the fence, to deter motorized trespass.

### 3. Time of Completion

- A. A Notice to Award is anticipated to be issued on or before May 21, 2026 to allow for initial preparations and submittal of work plans and preliminary mobilization. A Notice to Proceed is expected to be issued on May 21, 2026. All work must be completed by July 31, 2026.
- B. It is agreed by the parties to the contract case that in the case that all the work is not completed within the specified timeframes, damage will be sustained by the BCRCD; and that it would be impractical to ascertain actual damages and it is therefore agreed the Contractor will pay to the BCRCD the sum set forth herein per day for each working day delayed in completing the work in excess of the number of days prescribed; and the Contractor agrees to pay said liquidated damages and agrees that the BCRCD may deduct the amount thereof from money due or that may become due to the Contractor under the contract.
- C. The Contractor shall pay to the BCRCD the sum of five-hundred dollars (\$500.00) for each and every working day's delay in completing the work beyond the final completing dates specified above or as amended through Contract change order.

### 4. Pre-Bid/Site Walk

- A. There is a mandatory pre-bid/site walk offered for this project, which will be held Tuesday, April 21 at 9:00 am at the site.

### 5. Question Submission: **Thursday April 24th, 2026 at 5:00 PM.**

Contractors may submit questions by email to [wolfy@bcrd.org](mailto:wolfy@bcrd.org) before Thursday, April 24th, 2026 at 5:00 PM. All pertinent questions will be answered and shared via email with all of the other contractors who attended the mandatory pre-proposal site visit. The Contractor understands and agrees that it has a duty to inquire about and clarify any RFB questions that the Contractor does not fully understand or believes may be interpreted in more than one way. The BCRCD, however, is not required to answer questions that are not pertinent to the RFP or are considered to be proprietary information. Questions will be answered by Monday, April 28th, 2026, at 5 pm.

Please address questions to:  
Wolfy Rougle  
Email: [wolfy@bcrd.org](mailto:wolfy@bcrd.org)

## 6. Bid Due Date

- A. Proposals shall be received by the BCRCD on or before Thursday, May 7th, 2026 at 5:00 PM at the address above. Late submissions will not be accepted. Electronic submissions preferred. Bids will be publicly opened and read aloud outside of the BCRCD office at 5:00 PM PST on May 7, 2026.

## 7. Bid Review

- A. No bid proposal shall be considered as the successful bidder until after all bids have been reviewed by the BCRCD. If required by the BCRCD, the bidders shall submit any information requested to evaluate the bids, including Subcontractors, bond, cost breakdown, written bids, work experience, financial status, and status of license.

## 8. Bid Selection

1. No more than one (1) bid proposal from an individual, partnership, corporation, or association under the same or different names will be considered. Reasonable ground for believing that any bidder is interested in more than one (1) bid proposal for the work contemplated will cause rejection of all proposals in which such bidder is interested. If there is reason for believing that collusion exists among bidders, all bids will be rejected and none of the participants in such collusion will be considered in future proposals.

## 9. Bid Award

- A. Award of the contract, if awarded, will be made to the bid proposal which substantially complies with all of the requirements prescribed and is in the best interest of the BCRCD. Any such Award will be made within sixty (60) calendar days after the opening of the proposals. The BCRCD reserves the right to reject any and all bids, to waive any informality or irregularity in a bid, and to make award in the interests of the BCRCD.
- B. Between May 7 and May 21, the select Contractor shall receive a Notice of Intent to Award along with unsigned copies of the contract and other documents from the bid package.
- C. Within ten (10) calendar days of Notice of Award, and prior to any mobilization or ground-disturbing activity, the selected Contractor shall submit the written Naturally Occurring Asbestos (NOA) Compliance Commitment required under the NOA Compliance Narrative Requirement section of these specifications. The submission shall meet all requirements outlined in that section, including acknowledgment of applicability of Title 17 CCR §93105 and commitment to implement the required dust control measures. No mobilization, delivery of

equipment, staging, drilling, excavation, or other soil disturbance shall occur until BCRCDC has reviewed and accepted the Contractor's NOA Compliance Commitment. Failure to comply with the approved NOA Compliance Commitment or to maintain required dust control measures may result in suspension of work at the Contractor's expense.

- D. The bidder to whom award is made shall execute a written contract with the BCRCDC on the form of Agreement provided, and shall secure all insurance and bonds required by the Specifications. The Contractor shall not be permitted to proceed with the performance of the work unless and until it has obtained and provided evidence of insurance and bonds that satisfy and comply with the requirements of the Contract Documents. To the extent that the Contractor is delayed in obtaining or providing the required information, the Contractor shall be responsible for all such delays and shall not be entitled to additional time to complete the Contract within the specified timeframes.
- E. Failure or refusal to enter into a Contract within ten (10) calendar days following the receipt of the Notice of Intent to Award as herein provided, or to conform to any of the stipulated requirements in connection therewith, shall be just cause for annulment of the Award and the forfeiture of the proposal guarantee. If the successful bidder refuses or fails to execute the Contract, the BCRCDC may award the Contract to the bidder which provides the second amount of advantage to the BCRCDC. If the second bidder refuses or fails to execute the Contract, the BCRCDC may award the Contract to the bidder which provides the third amount of advantage to the BCRCDC, and so forth.

#### 10. Form of Agreement

- A. The form of Agreement, which the successful bidder will be required to execute, if awarded the work, is attached hereto and is made a part hereof.

#### 11. Wages

- A. The California General Prevailing Wage Determinations for crafts and associated with public works projects shall apply to this project. The expected wage classification relevant to the scope of work for this project is Laborer. In all instances where Federal and State Prevailing Wages for a given craft differ, the higher prevailing wage shall be paid. It shall be mandatory upon the contractors and all subcontractors to pay not less than said specified wages to all workers employed by them in the performance of this Contract. It shall also be mandatory upon the contractors and all the subcontractors to comply with all other California Labor Code or Federal rules regarding fringe benefits, the employment of apprentices, hours of labor, jobsite posting requirements, retention of payroll records, and debarment of contractors and subcontractors, to

the extent applicable. Copies of Certified Payroll reports for all Prevailing wage payroll paid by the contractors and any subcontractors shall be provided in a timely manner to the BCRC. The BCRC may withhold all or part of the applicable progress or final payment for the failure to submit complete and correct verified payrolls and related labor compliance documentation. Final payment may be withheld pending review and review of all Certified Payroll reports and all other required labor compliance documents.

- B. A copy of the current prevailing wage rates for this locality is available for the Department of Industrial Relations: [www.dir.ca.gov](http://www.dir.ca.gov).
- C. All bidders shall check the available source of labor supply and obtain information with reference to the working days of various crafts and the rates of wages being paid in the immediate vicinity of the place where the Work contemplated by these specifications is to be performed.
- D. It is intended that prevailing rates of wages and working hours shall be in accordance with those established by the jurisdictional authorities of the vicinity in which the Work is being performed. If the rates established are in excess of those prevailing, the prevailing rates shall govern, but in no instance shall the BCRC be held responsible for rates and wages paid which are below those prevailing.
- E. The project is subject to the requirements of Section 1770 et seq. of the California Labor Code requiring the payment of prevailing wages, the training of apprentices, and compliance with other applicable requirements. Contractors and all subcontractors who perform work on the project are required to comply with these requirements. Prevailing wage information for this project is available at: [www.dir.ca.gov](http://www.dir.ca.gov).
- F. This project requires full compliance by all contractors and subcontractors in accordance with the provision of Labor Code Section 1720 et seq. The Agency is required by law to review and audit the work performed on this project to ensure all prevailing wage and apprenticeship requirements are met. Specifically, contractors are reminded of the need for compliance with Labor Code Section 1774 (the payment of prevailing wage and the documentation of such) and Section 1811-1813 regarding the payment of overtime on public works projects.
- G. As a condition to receiving progress payments, or final payment and payment of retention on any and all projects on which the payment of prevailing wages is required, contractor shall submit all documentation (including certified payroll forms) required by the Labor Compliance program, as well as any additional

documentation requested by the Agency or its designee pursuant of Labor Code Section 1720 et. seq. BCRCDC shall withhold any portion of the payment, including the entire payment amount, until certified payroll forms and related documentation are properly submitted. In the event that certified payroll forms do not comply with the requirements of Labor Code Section 1720 et. seq., the Agency may continue to hold sufficient funds to cover estimated wages and penalties under the contract.

- H. Contractor or subcontractor is prohibited from inducing, by any means, any person employed in the construction, completion, or repair of public work, to give up any part of the compensation to which he or she is otherwise entitled. All suspected or reported violations will be reported to the U.S.D.A.
- I. Contractor shall compute the wages of every mechanic and laborer on the basis of a standard work week of 40 hours. Work in excess of the standard work week is permissible provided that the worker is compensated at a rate of not less than one and a half times the basic rate of pay for all hours worked in excess of 40 hours in the work week. The requirements of [40 U.S.C. 3704](#) are applicable to construction work and provide that no laborer or mechanic must be required to work in surroundings or under working conditions which are unsanitary, hazardous or dangerous.

#### 12. Withheld Contract Funds/Substitution of Securities

- A. The successful bidder shall be permitted to substitute securities for any moneys withheld by the BCRCDC to ensure performance under the executed Contract. At the request and expense of the successful bidder, securities equivalent to the amount to be withheld shall be deposited with the BCRCDC, or with a state or federally chartered bank in California as escrow agent, to ensure performance under the contract. Upon satisfactory completion of the Contract, unused securities shall be returned to the Contractor.
- B. Alternatively, on written request of the successful bidder, the BCRCDC shall make payment of the retention earnings directly to an escrow agent at the expense of the successful bidder. The successful bidder, at their expense, may direct the investment of the payment into securities and the successful bidder shall receive the interest earned on the investments on the same terms provided for securities deposited by Contract. Upon satisfactory completion of the Contract, the successful bidder shall receive from the escrow agent all the unused securities, interest, and payments received by the escrow agent from the BCRCDC.
- C. Securities eligible for deposits shall include those listed in Section 16430 of the Government Code, bond or savings and loan certificates of deposit, interest bearing demand deposit accounts, standby letter of credit, or any other security

mutually agreed to by the successful bidder and the BCRCD. The successful bidder shall be the beneficial owner of any securities substituted for moneys to be withheld, and shall receive any interest accrued upon the unused amount.

- D. If the security is deposited with a state or federally approved chartered bank as Escrow Agent, it is agreed that the successful bidder and the BCRCD will enter into an escrow agreement with the Escrow Agency in form substantially similar to that which is on file with the BCRCD and available for review.

### 13. Contractor Invoices and Payment

- A. Upon review and approval of work, payment shall be made by the BCRCD to Contractor within thirty (30) calendar days after BCRCD's receipt of payment from Funding Agency (USDA-Forest Service). Funds appropriated for this agreement are unavailable until BCRCD has submitted Contractor's invoice to Funding Agency, the agency has reviewed/ approved the invoice, and BCRCD has received payment. Invoices may be submitted at any time, but no more often than monthly.

### 14. Debarment Policy

- A. It shall be the policy of the Board of Directors of the BCRCD to prohibit any party or entity listed on the Excluded Parties System (EPLS), maintained by the General Services Agency of the United States Government, from participating in any Contract, agreement, or other business relationship with the BCRCD.

### 15. Non-Resident Contractor

- A. The State of California Franchise Tax Board requires that whenever payments are made to a non-resident, independent Contractor in excess of \$1,500 for services rendered, 7.0% of the gross amount must be withheld. A non-resident is anyone who is not a resident of California. A corporation is also subject to the withholding requirements if it is neither incorporated nor qualified to do business in the state of California. Unless the Franchise Tax Board has authorized a reduced rate or waiver of withholding and the BCRCD is provided evidence of such reduction/waiver, all nonresident Contractors will be subject to the withholding. It is the responsibility of the Contractor to submit the Waiver Request (Form 588) to the Franchise Tax Board as soon as possible in order to allow time for the Franchise Tax Board to review the request.

### 16. Public Works Contractor Registration Program

- A. No Contractor or subcontractor may be listed on a bid proposal for the public works project unless registered with the Department of Industrial Relations pursuant of Labor Code section 1725.5 [with limited exceptions from this requirement for bid purposes only under Labor Code section 1771.1 (a)].

- B. No Contractor or Subcontractor may be awarded a Contract for public works on a public works project unless registered with the Department of Industrial Relations pursuant to Labor Code section 1725.5.
- C. This project is subject to compliance monitoring and enforcement by the Department of Industrial Relations.

17. License

- A. The Contractor and all Subcontractors must be licensed under the laws of the State of California at the time this Contract is awarded, and for its full duration. The awarded Contractor shall possess a valid California Contractors License in a Classification that is relevant to the Scope or Work.

**END OF SECTION**

## SECTION 6: BID PROPOSAL FORM

(must be included in sealed bid)

Coutelenc Rd MacNab Fencing Project Bid Form

Item	Description	Quantity	Unit	Unit Price	Total
1	Mobilization	1	1	\$	\$
2	Asbestos Dust Mitigation Plan/ associated compliance costs				
3	Clearing <i>If contractor's technical approach requires clearing of vegetation beyond the 4' path already cleared, provide a bid for this clearing work.</i>		foot		
4	Construction of approximately 1,800 feet of fencing <i>(Please provide both a per-foot rate and a total estimate)</i>	1	Lump sum	\$	\$
5	Installation, using metal screws or bolts, of up to 48 12"x18" metal signs, directly to fence (signs will be furnished by BCRCB).	1	Per sign	\$	\$
	<b>TOTAL BID PRICE</b>				<b>\$</b>

Total Amount (written in words)

---

Authorized Contractor Signature

---

Date

---

[Continued on next page]

Contractor's Designated Representative

\_\_\_\_\_

Address

\_\_\_\_\_

\_\_\_\_\_

Telephone Number: \_\_\_\_\_

Cellphone Number: \_\_\_\_\_

California Contractors License Number: \_\_\_\_\_

### Technical Approach

Describe the technical approach you would use to fence this site. Your proposal should combine the elements of rock and metal pipe/bars in a way that meets all the following objectives: 1) fence, including its entrance, will effectively exclude OHVs/dirt bikes/motorized vehicles; 2) fence will be permanent and require a minimum of maintenance; 3) fence has an aesthetic appeal and blends into the unique, scenic site. You should provide a sketch. In your sketch, include dimensions or a range of dimensions. (The sketch does not need to be highly professional or look like an engineer's drawing!)

### **NOA Compliance Narrative Requirement**

Provide a written Naturally Occurring Asbestos (NOA) Compliance Narrative describing how you will protect your workers and the public from exposure to naturally occurring asbestos that may be present at the site. The scope of work likely includes advancement of approximately 180 post holes and associated limited soil disturbance activities. Your narrative shall reflect your specific technical approach and anticipated disturbance methods. A technical approach that includes drilling into rock or dry soils would be expected to result in different exposure prevention and dust control measures than an approach that minimizes disturbance.

A formal Asbestos Dust Mitigation Plan (ADMP) is **not** required for this project. However, compliance with Title 17 CCR §93105 (CARB ATCM) and Title 8 CCR §1529 remains mandatory.

At a minimum, your narrative shall acknowledge and commit to implementation of the following measures required by the County and consistent with Section E(1) of the ATCM:

- During construction activities, vehicles traveling across soils suspected or known to contain NOA must travel at speeds less than 15 mph, and if any dust is generated by vehicle movement, the roads shall be pre-moistened to prohibit dust from traveling across property boundaries.
- Prior to any ground disturbance, sufficient water must be applied to the area to be disturbed to prevent visible emissions from crossing the property line.
- Areas to be graded or excavated must be kept adequately wetted to prevent visible emissions from crossing the property line.
- Storage piles must be kept adequately wetted, treated with a chemical dust suppressant, or covered when material is not being added to or removed from the pile.
- Equipment must be washed down before moving from the property onto a paved public road.
- Visible track-out on paved public roads must be cleaned using wet sweeping or a HEPA filter-equipped vacuum device within twenty-four (24) hours.

The narrative shall also describe the engineering and administrative controls that will be implemented to minimize airborne fiber release, the criteria under which respiratory protection would be required, and how compliance documentation and required notifications will be managed.

BCRCD's Certified Asbestos Consultant (CAC) will conduct the Negative Exposure Assessment (NEA) and onsite air monitoring at the start of ground-disturbing activities and as necessary to

evaluate exposure conditions. You will coordinate with the CAC and comply with all exposure control recommendations and monitoring results. Coordination with the CAC does not relieve you of responsibility for maintaining required dust control measures and regulatory compliance throughout the project.

Bidder's List of Subcontractors

Subcontractor Name	Line Item and Description	Dollar Amount	Percentage of Total Bid Subcontracted	Contractor License Number

**Experience**

List **at least three (3)** construction projects that you recently completed (within the past five years) demonstrating similar tasks for a similar project in a similar rural setting. List any projects that are related to fence and/or gate installation. List the project name, contract amounts, and contacts of contract officers.

1) Job/Project Name \_\_\_\_\_  
 Owner \_\_\_\_\_ Year \_\_\_\_\_ Contract Amount \_\_\_\_\_  
 Contact Name \_\_\_\_\_ Phone \_\_\_\_\_  
 Project Description \_\_\_\_\_  
 \_\_\_\_\_

2) Job/Project Name \_\_\_\_\_  
 Owner \_\_\_\_\_ Year \_\_\_\_\_ Contract Amount \_\_\_\_\_

Contact Name \_\_\_\_\_ Phone \_\_\_\_\_  
Project Description \_\_\_\_\_  
\_\_\_\_\_

3) Job/Project Name \_\_\_\_\_  
Owner \_\_\_\_\_ Year \_\_\_\_\_ Contract Amount \_\_\_\_\_  
Contact Name \_\_\_\_\_ Phone \_\_\_\_\_  
Project Description \_\_\_\_\_  
\_\_\_\_\_

4) Job/Project Name \_\_\_\_\_  
Owner \_\_\_\_\_ Year \_\_\_\_\_ Contract Amount \_\_\_\_\_  
Contact Name \_\_\_\_\_ Phone \_\_\_\_\_  
Project Description \_\_\_\_\_  
\_\_\_\_\_

**END OF SECTION**

## **SECTION 7: NON-COLLUSION AFFIDAVIT**

**(must be included in sealed bid)**

TO BE EXECUTED BY THE BIDDER AND SUBMITTED WITH THE BID

To: Butte County Resource Conservation District

\_\_\_\_\_deposes and says that they are  
\_\_\_\_\_ (title) of \_\_\_\_\_, the party making the foregoing bid, that the bid is not made in the interest of, or on behalf of, any undisclosed person, partnership, company, association, organization, or corporation; that the bid is genuine and not collusive or sham; the bidder is not directly or indirectly induced or solicited with any other bidder to put in a false or sham bid, and has not directly or indirectly colluded, conspired, connived, or arranged with any bidder or anyone else to put in a sham bid, or that anyone shall refrain from bidding; that the bidder has not in any manner, directly or indirectly, sought by agreement, communication, or conference with anyone to fix the bid price, or of that of any bidder, or to secure an advantage against the public body awarding the contract of anyone interested in the proposed contract; that all statements contained in the bid are true and further, that the bidder has not directly or indirectly submitted their bid price or any breakdown thereof, or the contents thereof, or divulged information or data relative thereto, or paid, and will not pay any fee to any corporation, partnership, company association, organization, bid depository, or to any member or agent thereof to effectuate a collusive or sham bid.

The above certificate must be signed and filed with the BCRCD along with the bid

Signed \_\_\_\_\_ Date \_\_\_\_\_

**END OF SECTION**

## **SECTION 8: FIRE PLAN REVIEW AND ACKNOWLEDGEMENT**

**(Must be included in sealed bid)**

### **FIRE PLAN**

**See Attached Fire Plan**

*By signing below, the undersigned acknowledges receipt and review of the Fire Plan and affirms they understand and accept the duties, limitations, and requirements set forth herein, and agree to perform all activities in accordance with applicable laws, regulations, permits, and policies.*

**X**

\_\_\_\_\_  
Signature

## SECTION 9 - PERFORMANCE BOND

KNOW ALL PERSONS BY THESE PRESENTS: That, WHEREAS, the BUTTE COUNTY RESOURCE CONSERVATION DISTRICT (hereinafter called “BCRCD”), has conditionally awarded to (here insert full name and address or legal title of Contractor)

---



---



---

As Principal (hereinafter called “Contractor”) a Contract for “Coutelenc Rd MacNab Fencing Project”, in the said Butte County, in accordance with and consisting of the specifications prepared by BCRCD, which Contract also consists of all other parts of the Contract Documents for said project, which Contract is made a part hereof by reference, and is hereinafter referred to as the Contract, and WHEREAS said Contractor is required under the terms of said Contract to furnish a bond for the Faithful Performance of said Contract,

NOW, THEREFORE, we the Contractor and (here insert full name and address or legal title of Surety)

---



---



---

as Surety (hereinafter called “Surety”) are held and firmly bound unto the RCD of Butte County, Oroville, California in the sum of \_\_\_\_\_ Dollars (\$ \_\_\_\_\_), in lawful money of the United States, for the payment of which sum well and truly to be made Contractor and Surety bind themselves, their heirs, executors, administrators, successors and assigns, jointly and severally, firmly by these presents.

NOW, THEREFORE, THE CONDITION OF THIS OBLIGATION is such that, unless the above bounden Contractor, their heirs, executors, administrators, successors or assigns, shall in all things stand to and abide by, and will and truly keep and perform the covenants, conditions and agreements in additions or alterations thereof made as therein provided, on their part, to be kept and performed at the time and in the manner therein specified, and in all respects according to their true intent and meaning, and shall indemnify and save harmless the BCRCD, Architect/Engineer and their employees and their consultants, and their agents, as therein stipulated, then this obligation shall be null and void; otherwise it shall remain in full force and effect.

Contractor agrees not to assign this Contract except upon the written consent and approval of the BCRCD or their successor and assigns.

And Surety, for value received, hereby stipulates and agrees that no change, extension of time, alteration or addition to the terms of the Contract or to the work to be performed thereunder or the specifications accompanying the same shall in any way affect its obligations on this bond, and it does hereby waive notice of any such change, extension of time, alteration or addition to the terms of the Contract or to the work or to the specifications.

The Principal and Surety do hereby represent, warranty and guarantee, that the Surety is an "Admitted surety" as that term is, or may be, defined by California statute, regulation or the Department of Insurance.

IN WITNESS THEREOF, the above bounden parties have executed this instrument under their several seals this \_\_\_\_\_ day of \_\_\_\_\_, 20\_\_\_\_, the name and corporate seal of each corporate party being affixed hereto and these presents duly signed by its undersigned representatives, pursuant to its governing body.

SIGNED AND SEALED THIS \_\_\_\_\_ day of \_\_\_\_\_, 20\_\_\_\_\_.

\_\_\_\_\_  
Print name of Contractor

\_\_\_\_\_  
Surety Name

By: \_\_\_\_\_  
Signature

By: \_\_\_\_\_  
Attorney-in-Fact

\_\_\_\_\_  
Title of Signer

(Notary Acknowledgment Required )  
\_\_\_\_\_  
Title

(SURETY SEAL)

**END OF SECTION**

## SECTION 10 - CONTRACT AGREEMENT

THIS AGREEMENT, entered into as of \_\_\_\_\_ 2026, is between the Butte County Resource Conservation District, a public entity, organized and existing pursuant to the laws of the State of California (hereinafter called the "BCRCD") and \_\_\_\_\_. (Contractor License #\_\_\_\_), (hereinafter called the "Contractor"), WHEREAS, the Contractor has been awarded the contract for the work hereafter mentioned:

"Coutelenc Rd MacNab Fencing Project"

WITNESSETH: That the parties hereto mutually agree to the terms and conditions hereinafter set forth.

### I. CONTRACT DOCUMENTS

The Items hereinafter enumerated as the Contract Documents shall form a part of this Contract and the provisions thereof shall be as binding upon the parties hereto as if they were herein fully set forth. Work called for in any one Contract Document and not mentioned in another is to be performed and executed the same as if mentioned in all Contract Documents, the table of contents, titles, and headings contained herein and in said documents are solely to facilitate reference to various provisions of the Contract Documents and in no way affect or limit the interpretations of the provisions to which they refer.

The "Contract Documents", sometimes also referred to as the Contract, consist of the completed Form of Bid Proposal submitted by the Contractor to whom the Contract is awarded, the Instructions to Bidders insofar as they relate to events which will occur or actions to be taken after the submission of the Proposal, this Agreement to which the Conditions are attached, the General Conditions, the Supplementary Conditions, the Plans for Construction of the Coutelenc Rd MacNab Fencing Project and any modifications of any of the foregoing in the form of addenda or otherwise effected in accordance with the terms of the Contract.

### II. DEFINITIONS

Unless otherwise specifically provided herein, all words and phrases defined in the General Conditions shall have the same meaning and intent in this Agreement.

### III. SCOPE OF THE CONTRACT

The Contractor shall perform, within the time stipulated, the Contract as herein defined, and shall furnish all labor, tools, equipment, apparatus, facilities, labor and material and transportation necessary to perform and complete in a good workmanlike manner to the satisfaction of the BCRCD, all the work called for, and in the manner designated in, and in strict conformity with, the Contract Documents entitled: "Coutelenc Rd MacNab Fencing Project".

**By execution of the Agreement, the Contractor acknowledges that it has carefully reviewed and examined all Contract Documents, including all specifications, plans,**

addenda, and regulatory requirements referenced therein; has investigated the site conditions; and fully understands the scope of work and all obligations necessary to complete the Project in compliance with applicable laws and regulations. The Contractor further acknowledges that no claim for additional compensation or time will be considered based on failure to review or understand the Contract Documents or site conditions that were reasonably discoverable prior to bid submission.

#### IV. CONTRACT PRICE

The BCRCD agrees to pay and the Contractor agrees to accept, in full payment for the work included in the Bid the total sum of: (\$\_\_\_\_\_) (Amount in words).

#### V. CONTRACT TIME, COMPLETION, AND CHANGES

##### A. Notice to Proceed

Within fourteen (14) calendar days of the opening of bids the successful bidder will be authorized by written notice to proceed with the work. The bidder shall have no claim against the BCRCD, or its officers, employees, agents, consultants, project manager or engineer because of failure to issue the Notice to Proceed.

##### B. Commencement and Prosecution of Work

The Contractor shall commence the work on or before ten (10) days from and after the date specified in the written "Notice to Proceed," and will diligently prosecute the work to final completion. Said Notice to Proceed shall be issued following execution of the Agreement, the filing by the Contractor of the required bonds and proof of insurance. The continuous prosecution of work by the Contractor shall be subject only to delays as defined in this section of this Agreement.

##### C. Time of Completion

After given Notice to Proceed the entire work shall be brought to substantial completion in the manner provided for in the Contract Documents. Project work is to be performed during the working days and completed by July 31, 2026. The working days from and through the date of, shall be hereinafter called the "Estimated Completion Date" unless extensions of time are granted in accordance with the Contract Documents for Category A or B Delays as defined in this section of this Agreement. Failure to substantially complete the work within the above times and in the manner provided for by the Contract Documents shall subject the Contractor to liquidated damages as hereinafter stipulated in this Agreement. Time is and shall be of the essence of each and every obligation in these Contract Documents. The entire project must be completed by July 31, 2026, unless an extension is agreed on.

##### D. Changes in the Work

Changes in the work made and extensions of time of completion made necessary by reason thereof shall not in any way release any guarantee given by the Contractor pursuant to 5191 the provision of the Contract Documents, or the contract let hereunder, nor shall such changes in the work relieve or release the Sureties on bonds executed pursuant to the said provisions. The Sureties, in executing such bonds, shall be deemed to have expressly agreed to any such change in the work and to any extension of time made by reason thereof. The BCRCD agrees that no changes in the work shall be ordered which will necessitate an extension of the substantial completion time beyond the fixed completion date.

#### E. Extensions of Time

In the event it is deemed necessary by the BCRCDC to extend the time of substantial completion of the work to be done under this contract beyond any required dates of completion herein specified, such extensions shall in no way release any guarantee given by the Contractor pursuant to the provisions of the Contract Documents, or the contract let hereunder, nor shall such extension of time relieve or release the sureties on the bonds executed pursuant to said provisions. The sureties in executing such bonds shall be deemed to have expressly agreed to any such extension of time. The amount of time allowed in any Extension of Time shall be limited to the period of the delay-giving rise to the same as determined by the BCRCDC.

#### F. Labor Code Requirements/Prevailing Wages

This project is subject to the requirements of Section 1770 et seq. of the California Labor Code requiring the payment of prevailing wages, the training of apprentices and compliance with other applicable requirements. Contractors and all subcontractors who perform work on the project are required to comply with these requirements. Prevailing wage information for this project may be obtained via the internet at: [www.dir.ca.gov](http://www.dir.ca.gov).

This project is subject to the requirements of California Labor Laws as required by the California Labor Code. This requires full compliance by all contractors and subcontractors on the project in accordance with the provisions of Labor Code Section 1720 et. seq. The Agency is required by law to review and audit the work performed on this project to ensure that proper prevailing wages and all apprenticeship requirements are met. Specifically, contractors are reminded the need for compliance with Labor Code Section 1774 (the payment of prevailing wages and documentation of such), Section 1776 (the keeping and submission of accurate certified payrolls), Section 1777.5 in the employment of apprentices on public works projects and Section 1811-1813 regarding the payment of overtime on public works projects.

As a condition to receiving progress payments, final payment and payment of retention on any and all projects on which the payment of prevailing wages is required, the contractor agrees to present to the Agency or its designee, along with its request for payment, all applicable and necessary certified payrolls for the time period covering such payment request. The term "certified payroll" shall include all required documentation to comply with the mandated Labor Laws, as well as any additional documentation requested by the Agency or its designee pursuant to Labor Code Section 1720 et. seq.

The Agency shall withhold any portion of a payment, including the entire payment amount, until certified payroll forms and related documentation are properly submitted. In the event that certified payroll forms do not comply with the requirements of Labor Code Section 1720 et seq., the Agency may continue to hold sufficient funds to cover estimated wages and penalties under the contract.

The work herein described may fall into the category of public works projects for Federal and State requirements. CONTRACTOR shall abide by applicable Federal and State laws concerning the payment of prevailing wages (Labor Code Section 1720 et seq., including Sections 1771.5, 1720.4 and 1813; Public Resources Code Section 75075). The terms of this provision shall apply to any subcontracted labor used in the execution of this agreement. Contractor is required to comply with all of the terms and conditions

(including Federal and State General Prevailing Wage requirements) prescribed for contractors performing public works projects. If federal funding is incorporated in this project, the contract requirements of the Davis-Bacon and Related Acts ([40 U.S.C. 3141-3144](#), and [3146-3148](#)) and a copy of the applicable federal wage determination shall be attached as an Appendix to this agreement.

The California General Prevailing Wage determinations for crafts associated with public works projects shall apply to this project. In all instances where Federal and State Prevailing Wages for a given craft differ, the higher Prevailing Wage shall be paid. The expected wage classification relevant to the scope of work for this project is Laborer. It shall be mandatory upon the Contractor and all subcontractors to pay not less than the said specified rates to all workers employed by them in the performance of this contract. It shall also be mandatory upon the Contractor and all subcontractors to comply with all other California Labor Code or Federal requirements, which include, but are not limited to, required reporting, payment of fringe benefits, the employment of apprentices, hours of labor, jobsite posting requirements, retention of payroll records and debarment of contractors and subcontractors, to the extent applicable. Copies of Certified Payroll reports for all Prevailing Wage payroll paid by the CONTRACTOR and any subcontractors shall be provided in a timely manner to BCRCD. BCRCD may withhold all or part of applicable progress or final payments for the failure to submit complete and correct certified payrolls and related labor compliance documentation. Final payment may be withheld pending receipt and review of all Certified Payroll reports and all other required labor compliance documents.

Contractor agrees, in accordance with Section 1771.1 of the California Labor Code, that contractor or subcontractor shall not be qualified to bid on, be listed in a bid proposal, subject to the requirements of Section 4104 of the Public Contract Code, or engage in the performance of any contract for public work, as defined in this chapter, unless currently registered and qualified to perform public work pursuant to Section 1725.5. It is not a violation of this section for an unregistered contractor to submit a bid that is authorized by Section 7029.1 of the Business and Professions Code or by Section 10164 or 20103.5 of the Public Contract Code, provided the contractor is registered to perform public work pursuant to Section 1725.5 at the time the contract is awarded.

No contractor or subcontractor may be awarded a contract for public work on a public works project (awarded on or after April 1, 2015) unless registered with the Department of Industrial Relations pursuant to California Labor Code section 1725.5. Contractor agrees, in accordance with Section 1771.4 of the California Labor Code, this Project is subject to compliance monitoring and enforcement by the Department of Industrial Relations.

This project is subject to compliance monitoring and enforcement by the Department of Industrial Relations.

#### G. Category A Delays

For the purpose of these Contract Documents, the term "Category A Delays" shall mean, and is limited to, delays caused directly by acts of God; acts of the public enemy; fire, riots, insurrections; epidemics; quarantine restrictions; strikes; lockouts; sit-downs; acts of a governmental agency; priorities or privileges established for the manufacture, assembly

or allotment of materials necessary in the construction of the work by order, decree or otherwise of the United States or by any department, bureau, commission, committee, agent, or administrator of any legally constituted public authority; changes in the work ordered by the BCRCD insofar as they necessarily require additional time in which to substantially complete the work; the prevention by the BCRCD of the Contractor from commencing or prosecuting the work because of the acts of others, excepting the Contractor's subcontractors; or the prevention of the Contractor from commencing or prosecuting the work because of a city-wide failure of public utility service. Inclement weather shall not be a prima facie reason for the granting of an extension of time, and the Contractor shall make every effort to continue work under prevailing conditions. The BCRCD may, however, grant an extension of time if an unavoidable delay as a result of inclement weather in fact occurs, and such shall then be classified as a "Category A Delay". The term "Category A Delay" shall specifically not include (i) any delay which could have been avoided by the exercise of care, prudence, foresight and diligence on the part of the Contractor; (ii) any delay in the prosecution of parts of the work, which may in itself be unavoidable but which does not necessarily prevent or delay the prosecution of other parts of the work, nor substantial completion of the whole work within the time specified; (iii) any reasonable delay resulting from time required by the BCRCD for review of plans submitted by the Contractor and for the making of surveys, measurements and inspection; and (iv) any delay arising from an interruption in the prosecution of the work on account of the reasonable interference from other contractors employed by the BCRCD which does not necessarily prevent the completion of the whole work within the time specified.

#### H. Category B Delays

For the purposes of these Contract Documents, the term "Category B Delays" shall mean delays caused directly by loss or damage to the project caused by the perils covered by the Builder's Risk insurance (if any) provided for by the Agreement or by any war declared by an enactment of the Congress of the United States of America.

#### VI LIQUIDATED DAMAGES

The provisions for Liquidated Damages appearing in the Instructions to Bidders are incorporated by reference as if fully set forth herein. Liquidated damages of \$500.00 per day will be charged to the Contractor for each day of delay beyond the substantial completion date.

#### VII NOTICE OF DELAY

The Contractor shall promptly notify the BCRCD in writing of any anticipated delay in the prosecution of the work, and, in any event, promptly upon the occurrence of a delay. Said notice shall constitute an application for an extension of contract time only if it is reviewed and approved by the BCRCD Board of Directors. Failure by the Contractor to make a timely request will result in a waiver of the right to such extension. The BCRCD

may take steps to prevent the occurrence of continuance of the delay and/or may determine to what extent the completion of the work is delayed thereby.

**VIII NO WAIVER OF RIGHTS**

Neither the inspection by the BCRCD or its agents, nor any order or certificate for the payment of money, nor any payment for, nor acceptance of the whole or any part of the work by the BCRCD, nor any extensions of time, nor any position taken by the BCRCD or its agents shall operate as a waiver of any provision of this Contract, or of any power herein reserved to the BCRCD or any right to damage herein provided, nor shall any waiver of any breach of this Contract be held to be a waiver of any other or subsequent breach. All remedies provided in this Contract shall be taken and construed as cumulative, that is in addition to each and every other remedy herein provided; and the BCRCD shall have any and all equitable and legal remedies which it would in any case have.

**IX AGREEMENT CONTROLS**

In the event of a conflict between the Contract Documents, the conflict shall be resolved by giving precedence in the following order: (1) This Agreement Form; (2) the Notice to Contractors; (5) the Instructions to Bidders; (6) the Construction Requirements text.

**CONTRACT AGREEMENT CERTIFICATION**

BCRCD

Signature: \_\_\_\_\_ Date: \_\_\_\_\_

Printed Name: \_\_\_\_\_ Title: \_\_\_\_\_

Contractor

Signature: \_\_\_\_\_ Date: \_\_\_\_\_

Printed Name: \_\_\_\_\_ Title: \_\_\_\_\_

Company: \_\_\_\_\_

**END OF SECTION**



## **SECTION 11 - GENERAL CONDITIONS**

### **ARTICLE 1 - DEFINITIONS**

Whenever used in these General Conditions or in the other Contract Documents, the following terms have the meanings indicated which are applicable to both the singular and plural thereof:

1.1 Agreement - The written and signed contract between the BCRCDC and the General Contractor that is entitled "Agreement."

1.2 Application for Payment - The form furnished by the BCRCDC to be used by the Contractor in requesting progress payment. This includes the schedule of values and an affidavit of Contractor that progress payments received on account of the work have been applied by Contractor to discharge in full all of the Contractor's obligations as reflected in prior Applications for Payment and otherwise.

1.3 Airborne Toxic Control Measure (ATCM) – The California regulation codified at Title 17 CCR §93105 governing construction, grading, quarrying, and surface mining operations in areas containing Naturally Occurring Asbestos.

1.4 Architect/Engineer - The person licensed by the State of California (architect or engineer) who is fully responsible for the Contract Drawings and Project Manual, Addenda and modifications.

1.5 Asbestos – The asbestiform varieties of serpentine (chrysotile) and amphibole minerals including actinolite, amosite, anthophyllite, crocidolite, and tremolite, as defined under Title 8 CCR §1529 and 29 CFR §1926.1101

1.6 Asbestos Dust Mitigation Plan (ADMP) – A written plan required under Title 17 CCR §93105 for certain construction or grading projects in NOA areas that describes required dust control measures, work practices, and recordkeeping procedures.

1.7 Bid - The offer or proposal of the bidder submitted on the prescribed form setting forth the prices for the work to be performed.

1.8 Bidder - Any person, firm or corporation, licensed in the State of California, submitting a bid for the work.

1.9 Bonds - Bid, performance, and labor and material payment bonds and other instruments of security, including lien and stop-notice bonds, furnished by the Contractor and their Surety in accordance with the Contract Documents.

1.10 Butte County Resource Conservation District (BCRCD) – a non-regulatory public agency (special district) organized and existing pursuant to the laws of the State of California whose mission is “to protect, enhance, and support Butte County natural resources and agriculture by working with willing land owners and citizens through education, land management, and on-the-ground projects.”

1.11 Calendar Day (or "Day") - A day of twenty-four hours measured from one midnight to the next midnight, Pacific Time. Unless otherwise indicated, a "day" shall mean a calendar day.

1.12 Certified Asbestos Consultant (CAC) – An individual certified by the State of California pursuant to Title 8 CCR §1529 and related regulations, qualified to perform asbestos consulting services including monitoring and exposure assessment.

1.13 Change Order - A written order, issued by the Project Manager to Contractor, signed by the Project Manager, Engineer and BCRCD authorizing an addition, deletion or revision in the work, or an adjustment in the contract price or the contract time.

1.14 Contract Completion Date - The date established in the Contract Documents for the completion of the construction phase of the project, namely, the Estimated Completion Date and Fixed Completion Date.

1.15 Contractor - The person, firm or corporation with whom BCRCD has executed the Agreement and who is fully responsible for the performance of the work.

1.16 Contract Documents - The Agreement, Addenda, Contractor's Bid, the Bonds, and Notice of Award, these General Conditions, Supplementary Conditions, Specifications, Plans, Drawings and Modifications. The Contract Documents form the Contract for Construction. This Contract represents the entire and integrated agreement between the parties and supersedes all prior negotiations, representations, or agreements, either written or oral. The Contract may be modified or amended only by a Modification as defined in these General Conditions.

1.17 Contract Price - The total amount stated in the Agreement as payable to Contractor for the performance of the work under the Contract Documents, including authorized adjustments thereto.

1.18 Contract Time - The total amount stated in the Agreement for the completion of the work.

1.19 County – County of Butte, a public entity organized and existing pursuant to the laws of the State of California.

1.20 Drawings - The drawings and/or plans which show the character and scope of work to be performed, and which have been prepared or approved by the Architect / Engineer and are referred to in the Contract Documents.

1.21 Excursion Limit (EL) – The maximum short-term exposure limit for asbestos established under Title 8 CCR §1529, defined as 1.0 fibers per cubic centimeter of air averaged over a 30-minute sampling period.

1.22 Field Order - A written order issued by the Project Manager which clarifies or interprets the Contract Documents in accordance with paragraph 9.2, or orders minor changes in the work in accordance with paragraph 11.3.

1.23 Furnish - To “supply and deliver to the Project site, ready for unloading, unpacking, assembly, installation, and similar operations.”

1.24 General Conditions - That part of the Contract Documents which sets forth many of the rights, responsibilities and relationships of the parties involved or of the contract.

1.25 General Requirements - The General Requirements are contained in Construction Specifications of the “Coutelenc Rd MacNab Fencing Project” in these Contract Documents. The General Requirements are the administrative functions which the Contractor is bound to perform by the Contract.

1.26 Inspector - An authorized representative of the BCRCDD who is assigned to make a detailed inspection of any or all portions of the work or materials thereof.

1.27 Install - Describes operations at project site including the actual “unloading, unpacking, assembly, erection, placing, anchoring, applying, working to dimension, finishing, curing, protecting, cleaning, and similar operations.”

1.28 Instructions to Bidders - That part of the Bidding Requirements which contain the format of the bid, and the availability of the Contract Documents.

1.29 Naturally Occurring Asbestos (NOA) – Asbestos-containing minerals found in natural geologic formations such as rock, soil, or sediment that have not been manufactured or intentionally added to a product.

1.30 Negative Exposure Assessment (NEA) – A demonstration, in accordance with Title 8 CCR §1529, that employee exposures during a specific asbestos-related task are expected to be consistently below the permissible exposure limit under worst-case conditions.

1.30 Notice of Award - The written notification to the Contractor from the BCRCDD of its intent to execute the Contract.

1.31 Notice to Bidders - A notice contained in the Bidding Requirements informing prospective bidders of the opportunity to submit bids on a project and setting forth the procedures for doing

so.

1.32 Notice to Proceed - The written notice given by the BCRCD to Contractor fixing the date on which Contractor shall start to perform their obligation under the Contract Documents.

1.33 O.P.C.I. – “Owner” (in this case, BCRCD) purchased/Contractor receives, stores, and installs.

1.34 Per - In accordance with or in compliance with.

1.35 Permissible Exposure Limit (PEL) – The allowable employee exposure limit for asbestos established under Title 8 CCR §1529, defined as 0.1 fibers per cubic centimeter of air as an 8-hour time-weighted average.

1.36 Progress Payment - Payment for work completed by measuring the work in place and applying the percentage complete of the measured amount to a previously agreed unit cost to determine the total payment.

1.37 Project - The entire work to be performed as provided in the Contract Documents.

1.38 Project Manager - The authorized representative of the BCRCD.

1.39 Project Manual - A part of the Contract Documents containing Introductory Information, Bidding Requirements, Contracting Requirements, Specifications, and Opening and Room Finish Schedules bound in one or more volumes.

1.40 Project Work Schedule - A diagram showing proposed times of starting and completing various elements of the work.

1.41 Provide - “To furnish and install, complete and ready for the intended use.”

1.42 Punch List - A list, made near the completion of work, indicating items to be furnished or work to be performed by the Contractor or Subcontractor in order to complete the work as specified in the Contract Documents.

1.43 Schedule of Values - A statement furnished by the Contractor to the Project Manager reflecting the portions of the contract sum allotted for the various parts of the work.

1.44 Shop Drawings - All drawings, diagrams, illustrations, brochures, schedules and other data which are prepared by the Contractor, a subcontractor, manufacturer, supplier or distributor and which illustrate in detail the equipment, material or some portion of the work.

1.45 Specifications - The portion of the Contract Documents consisting of written technical

descriptions of materials, equipment, construction systems, standards and workmanship as applied to the work.

1.46 Subcontractor - An individual, firm or corporation having a direct contract with the Contractor, or with any other subcontractor, for the performance of a part of the work.

1.47 Substantial Completion, Date of - The date as certified by the BCRCDD in a Notice of Completion pursuant to paragraph 14.8 of these General Conditions.

1.48 Work - The completed construction in the manner required by the Contract Documents. This includes without limitation all labor, services, and supervision necessary or appropriate to produce such construction, all materials, supplies and equipment incorporated or to be incorporated in such construction, and all obligations, duties and responsibilities with respect to such construction set forth in the Contract Documents.

1.49 Working Day - Any day not a legal holiday, Saturday or Sunday

## **ARTICLE 2 - PRELIMINARY MATTERS**

### 2.1 Execution of Agreement:

2.1.1 The Agreement and such other Contract Documents as designated by the BCRCDD, shall be executed and delivered by the Contractor to the BCRCDD within ten (10) days of the Notice of Award. BCRCDD will execute and deliver one counterpart to Contractor within five (5) days of receipt of the executed Agreement from Contractor.

### 2.3 Copies of Documents:

2.3.1 BCRCDD shall furnish to Contractor 2 copies of the Contract Documents for the execution of the work. Additional copies will be furnished at cost of reproduction upon request.

### 2.4 Contractor's Pre-Start Representations:

2.4.1 Contractor represents that they has familiarized themselves with, and assumes full responsibility for having familiarized themselves with, the nature and extent of the Contract Documents, work, locality and with all local conditions including federal, state and local laws, ordinances, rules and regulations that may in any manner affect performance of the work, and represents that they have correlated their study and observations with the requirements of the Contract Documents.

2.4.2 Contractor also represents that they have familiarized themselves with all surveys and investigation reports of surface and latent physical and that they have correlated the results of all such data with the requirements of the Contract Documents.

## 2.5 Commencement of Time; Starting the Project:

2.5.1 The contract time will commence on the date fixed by the Notice to Proceed. The Contractor shall start to perform the work under the Contract Documents on or before the tenth working day after the date assigned in the Notice to Proceed.

## 2.6 Before Starting Construction:

2.6.1 The Contractor shall carefully study and compare the Contract Documents; check and verify pertinent figures shown thereon; and verify all applicable field measurements prior to undertaking each part of the work. They shall at once report in writing to the Project Manager any conflict, error or discrepancy which they may discover. Contractor shall be responsible for exercising reasonable care and skill in reviewing the Contract Documents to determine whether there is any conflict, error or discrepancy therein, and shall be responsible for notifying the Project Manager. No claim for additional compensation shall be made by the Contractor for extra work created by Contract Document conflicts, errors or discrepancies which a reasonable Contractor would have discovered prior to commencing work.

2.6.2 The Contractor shall furnish the BCRCDD all certificates of insurance required by the Contract Documents after the "Notice of Conditional Award" and prior to the "Notice to Proceed," in types and amounts set forth in Article 5.

## **ARTICLE 3 - CORRELATION, INTERPRETATION, AND INTENT OF CONTRACT DOCUMENTS**

3.1 It is the intent of the Contract Documents to describe a complete project to be constructed. As stated in paragraph 1.12, the Contract Documents comprise the entire contract between BCRCDD and Contractor. They may be altered only by a Modification, as defined in paragraph 1.12.

3.2 The Contract Documents are complementary, and what is required by any one shall be as binding as if required by all. Work not specifically covered in the Contract Documents shall nonetheless be required if it is consistent therewith and is reasonably inferable therefrom as being necessary or appropriate to produce the intended results. Should the Contractor discover a conflict, error, or discrepancy in the Contract Documents, they shall immediately call it to the attention of the BCRCDD in writing before proceeding with the work affected. Contractor agrees that proceeding with work without first giving such notice shall constitute a waiver by Contractor of any claim for additional time or money. Where there is a conflict, the Contract Documents, Specifications shall govern over the drawings; figure dimensions and drawings shall govern over scale drawings. Words and abbreviations that have technical or trade meanings are used in the Contract Documents in accordance with such recognized meanings.

## **ARTICLE 4 - AVAILABILITY OF LANDS, PHYSICAL CONDITIONS, AND REFERENCE POINTS**

### Availability of Lands:

4.1.1 BCRCD shall furnish the lands upon which the work is to be done, right-of-way for access thereto, and other such lands which are designated in the Contract Documents for the use of the Contractor. Contractor shall provide all additional lands and access thereto that may be required for temporary construction facilities or storage of materials and equipment.

### 4.2 Physical Conditions:

4.2.1 The Contractor shall immediately, and before any such conditions are disturbed, notify the Project Manager in writing of subsurface or latent physical conditions at the site differing materially from those indicated in the Contract Documents; or unknown and unforeseen physical conditions at the site, of an unusual nature, differing materially from those ordinarily encountered and generally recognized as inherent in work of the character provided for in the Contract Documents. The Project Manager shall promptly investigate the conditions, and if they find that such conditions do materially so differ to cause an increase or decrease in the time required for performance of the work, an appropriate adjustment in Contract Time may be made in accordance with Article 12 of these General Conditions. The Contract Documents may be modified by Change Order accordingly. In no event shall Contractor be entitled to increased compensation for such differing conditions, unless provided for in such Change Order.

4.2.2 No increase of time under paragraph 4.2.1 shall be allowed unless the Contractor shall have given the written notice described in paragraph 4.2.1 not later than 24 hours after such conditions are discovered, and before such conditions are disturbed. Contractor shall not proceed with the work affected by such conditions until directed in writing by Project Manager. Furthermore, no increase shall be given unless it is shown that Contractor's own investigation was done competently and did not disclose the error or condition. Failure of Contractor to give written notice and providing an opportunity for the Project Manager to investigate shall constitute a waiver by Contractor of any claim for additional time or money.

## **ARTICLE 5 - BONDS AND INSURANCE**

5.1.1 Contractor shall obtain and maintain continuously comprehensive general liability insurance and/or other insurance necessary to protect the public with limits of liability of not less than \$1,000,000 combined single limit bodily injury and property damage per occurrence with a \$1,000,000 combined single limit annual aggregate with appropriate coverage endorsements to include broad-form contractual, broad form property damage, contractor's protective, product/completed operations, auto and non-owned auto, personal injury, and fire-legal liability where applicable. The general aggregate limit shall apply separately to this project, or Contractor shall provide insurance with a general aggregate limit of \$2,000,000. Such insurance

shall include “BCRCD, its elected officials, officers, and employees as an additional insured”, and shall not be reduced or canceled without 30 days written prior-notice certain to the BCRCD. Contractor shall provide the BCRCD a certificate of insurance and an additional insured endorsement as evidence of insurance protection provided which lists “BCRCD of Butte County” as the certificate holder. Insurance certificates provided by any insurance company or underwriter shall not contain the language “endeavor to” and “but failure to mail such notice shall impose no obligation or liability of any kind upon the company”, or similar language. If Contractor has employees, they shall obtain and maintain continuously workers' compensation insurance to cover Contractor and Contractor's employees and partners.

5.1.2 The Contractor, upon notification of receipt by the BCRCD of any cancellation notice shall file with the BCRCD a replacement certificate with another insurance company meeting the financial requirements of the BCRCD and the coverage requirements. Failure to maintain any of the above required insurance shall require the immediate discontinuation of work until replacement insurance is furnished to the BCRCD. All payments due or that become due will be withheld until notice of replacement is received. Any failure to maintain insurance will be sufficient cause for termination of the contract.

5.1.3 Automobile Liability Insurance: Contractor shall carry Bodily injury and Property Damage liability including coverage for owned, hired and non-owned automobiles. The limits of liability shall be not less than \$1,000,000 Bodily Injury, \$300,000 Property Damage or \$1,000,000 Combined Single Limit Bodily Injury and Property Damage.

5.1.4 As evidence of the insurance required by this agreement, certificates of workers compensation, general liability and automobile liability shall be furnished to the BCRCD before any work is commenced by the Contractor.

5.2 Builders Risk Insurance: The Contractor will not be required to obtain Builder's Risk Insurance. The Contractor will be responsible for building materials not installed and for the Contractor's tools, other equipment or supplies. The Contractor shall also be required to protect the construction project as stipulated elsewhere in this contract.

5.4 Responsibility for Damage:

5.4.1 Approval of the Contractor's insurance by the BCRCD shall not decrease the extent to which the Contractor or any subcontractor may be held responsible for payment of any and all damages resulting from Contractor's operations.

5.4.2 The Contractor shall assume the defense of and indemnity and save harmless the BCRCD, its elected officials, officers and employees, as well as the Project Manager, Engineer and the officers, agents and employees of each of them, from any and all loss, liability or damage including attorney's fees and from all suits, actions, damages or claims of every nature and description to which they may be subjected or put by reasons of injury to persons or

property arising out of, in connection with, or incident to the execution of the work or resulting from the active or passive negligence or carelessness on the part of the Contractor, Contractor's employees or agents in the delivery of materials and supplies by its employees or agents, including any failure to fulfill the terms of all laws and regulations which apply to this Contract together with any infringement or alleged infringement of the patent rights of any person or persons, firm or corporation in consequence of the use in or about the said work of any article or materials; and the BCRCDC shall have the right to estimate the amount of such damage and to cause the Contractor to pay same, and the amount to be paid for such damage shall be deducted from the money due to the Contractor under this Contract; or the whole or so much of the money due or to become due to the Contractor under this Contract, as may be considered necessary by the BCRCDC, shall be retained by the BCRCDC until such suits or claims for damages shall have been settled or otherwise disposed of and satisfactory evidence to that effect furnished to the BCRCDC. Contractor shall assume the defense of and indemnify and save harmless BCRCDC, its elected officials, officers and employees, as well as the Engineer, Project Manager and the officers, agents and employees of each of them in respect to any mechanics lien, foreclosure actions filed by any subcontractor or material person relative to the construction.

## **ARTICLE 6 - CONTRACTOR'S RESPONSIBILITIES**

### 6.1 Supervision and Superintendent:

6.1.1 Contractor shall supervise and direct the work effectively, efficiently and with their best skill and attention. They shall have sole responsibility for the means, methods, techniques, sequences, procedures of construction, and for coordinating all portions of their work under the Contract Documents. Contractor shall be responsible for the finished work complying accurately with the Contract Documents.

6.1.2 The Contractor shall designate in writing, before starting work, the name, qualifications and experience of their proposed representative who must be approved by the Project Manager. Said representative shall have authority to represent and to act for the Contractor. Said authorized representative shall be present at the site of work at all times while work is in progress. Arrangements for responsible supervision, acceptable to Project Manager, shall be made for emergency work required during periods when work is suspended.

6.1.3 The Contractor shall notify the Project Manager, in writing, when they desire to change their representative. They shall provide all necessary information regarding their new representative when submitting request for approval. Any substitute representative shall require the approval of the Project Manager, which may not be unreasonably withheld.

6.1.4 In emergencies when the Contractor or their authorized representative is not present on any particular part of the work, directions will be given by the Project Manager and obeyed by

the superintendent or foreperson in charge of the particular work. Such directions will be confirmed in writing to the Contractor's authorized representative.

6.1.5 The Contractor shall identify, in writing, the individuals who are authorized to sign Change Orders to the Contract.

6.1.6 The Contractor shall remove their representative from the work and propose a substitute if Project Manager reasonably concludes that such representative is unable or unwilling to properly supervise the work in such a manner as to ensure its timely and successful completion in accordance with Contract Documents.

6.1.7 The Contractor shall maintain daily job site activity logs which record: location and number of all manpower on the site by their own and subcontractors' forces; all work being performed and whether such work is part of the base contract or change order; all construction equipment in use, and not in use, and reasons why not in use; weather and site conditions; and delays or obstructions to the work. The Contractor shall sign the log representing that the information contained therein is true, accurate and complete.

### 6.3 Labor, Materials and Equipment:

6.3.1 Contractor shall provide competent, suitable qualified personnel to survey and lay out the work and perform construction as required by the Contract Documents. Contractor shall at all times enforce strict discipline and good order on the project. They shall not employ on the work any unfit person or anyone not skilled in the task assigned to them.

6.3.2 Contractor shall furnish all equipment, labor, transportation, and machinery, tools, appliances, other facilities and incidentals necessary for the execution, testing, initial operation and completion of work.

6.3.4 All materials and equipment shall be applied, installed, connected, erected, used, cleaned and conditioned in accordance with the instruction of the applicable manufacturer, fabricator or processors.

### 6.5 Subcontractors:

6.5.1 Contractor shall investigate and assure themselves and the BCRCD of the experience and skill of all subcontractors performing work specified by the Contract Documents as well as the financial stability of such subcontractors. Contractor shall not recommend any subcontractor or other person or firm, whether initially or as a substitution against whom BCRCD, at BCRCD's sole discretion, may have reasonable objection. If BCRCD who has no duty to investigate, but has the right to do so, after due investigation, has a reasonable objection to any subcontractor, supplier or material person proposed by Contractor, Contractor shall propose an acceptable

substitute. Contractor shall be fully responsible for all acts and omissions of their subcontractors, and of persons and organizations directly or indirectly employed by them and of persons and organizations for whose acts any of them may be liable to the same extent that they are responsible for the acts and omissions of persons directly employed by them. Nothing in the Contract Documents shall create any contractual relationship between the BCRCD, Project Manager or Engineer and any subcontractor, or other person or organization having a direct contact with the Contractor, nor shall it create any obligation on the part of BCRCD, Project Manager or Engineer to pay or see to the payment of any monies due any subcontractor or other persons or organizations.

6.5.3 The divisions and sections of the Specifications and the identifications of any Drawings shall not control the Contractor in dividing the work among subcontractors or delineating the work to be performed by any specific trade. Neither the Engineer, nor Project Manager, nor BCRCD will act as arbiter to determine subcontract limits.

6.5.4 Contractor agrees to bind specifically every subcontractor to the applicable terms and conditions of the Contract Documents for the benefit of the BCRCD including, but not limited to, all time and notification requirements.

6.5.5 All work performed for Contractor by a subcontractor shall be pursuant to an appropriate agreement between Contractor and subcontractor which shall contain provisions for the waiver of all rights the contracting parties may have against one another for damages caused by fire or other perils covered by insurance. Contractor shall pay each subcontractor a just share of any such insurance moneys received by Contractor.

#### 6.6 Patent Fees and Royalties:

6.6.1 Contractor shall pay license fees and royalties and assume all costs incident to the use, in the performance of the work, of any invention, design, process, product or device which is the subject of patent rights or copyrights held by others. If a particular invention, design, device or product is specified in the Contract Documents for use in the performance of the work, and to the actual knowledge of BCRCD and Engineer its use is subject to patent rights or copyrights calling for the payment of any license fee or royalty to others, the existence of such rights shall be disclosed by BCRCD in the Contract Documents. Contractor shall indemnify and hold harmless BCRCD, Project Manager, their employees, officers and agents, and Engineer, their consultants, and anyone directly or indirectly employed by either of them from and against consultants' and other experts' fees and expenses arising out of any infringement of patent rights incident to the use in the performance of the work or resulting from the incorporation in the work of any invention, design, process, product or device not specified in the Contract Documents, and shall defend all such claims in connection with alleged infringement of such rights.

#### 6.8 Laws and Regulations:

6.8.1 Contractor shall give notices and comply with all laws, ordinances, rules and regulations applicable to the work. Contractor shall use reasonable care and skill in determining whether or not the Specifications or Drawings are at variance therewith, and, if they observe such variance, they shall give the Project Manager and Engineer prompt written notice thereof. If Contractor performs any work knowing it to be contrary to such laws, ordinances, rules and regulations, and without such notice to the Project Manager and Engineer, they shall bear all costs arising therefrom.

#### 6.9 Taxes:

6.9.1 Contractor shall pay all sales, consumer use and other similar taxes required to be paid by them in accordance with the law of the place where the work is to be performed.

#### 6.10 Use of the Premises:

6.10.1 Contractor shall confine their equipment, the storage of materials and equipment and the operations of their workcrew to areas permitted by law, ordinance, permits or the requirements of the BCRCDC and of the Contract Documents, and shall not unreasonably encumber the premises with materials or equipment.

6.10.2 Contractor shall not load nor permit any part of any structure to be loaded with weight that will endanger the structure, nor shall they subject any part of the work to stresses or pressure that will endanger it.

#### 6.12 Safety and Protection:

Contractor shall be responsible for initiating, maintaining, and supervising all safety precautions and programs in connection with the work. They shall take all necessary precautions for the safety of, and shall provide the necessary protection to prevent damage, injury or loss to:

6.12.1.1 All employees on the work and other persons who may be affected thereby:

6.12.1.2 All the work and all materials or equipment to be incorporated therein, whether in storage on or off the site; and

6.12.1.3 Other property at the site or adjacent thereto, including trees, shrubs, lawns, pavements, roadway, structures and utilities not designated for removal, relocation or replacement in the course of construction.

6.12.1.4 The Contractor represents that they have read and is thoroughly familiar with the California State Occupational Safety and Health Act, and regulations for construction promulgated thereunder, and agrees to comply with the Act and all such regulations applicable

to the performance of the work. The Contractor accepts the duty of enforcing those regulations by federal, state or BCRCD Safety and Health Inspectors at the Contractor's work place at the job site or any area within the limits of construction and of the outcome of any such inspections. Contractor assumes exclusive responsibility for, and agrees to defend, indemnify and hold harmless the BCRCD, Project Manager, Engineer, and their elected officials, officers, agents, employees, consultants and representatives against all consequences of any violations of those regulations by the Contractor, including the payment of any fine, penalty and interest assessed in connection therewith, any court costs, undertakings, interest, and attorneys', accountants' consultants' and experts' expenses and fees incurred by the BCRCD.

6.12.2 Contractor shall comply with all applicable laws, ordinances, rules, regulations and orders of any public body having jurisdiction for the safety of persons or property or to protect them from damage, injury or loss. They shall erect and maintain, as required by the conditions and progress of the work, all necessary safeguards for its safety and protection. They shall notify BCRCD of adjacent utilities when prosecution of the work might affect them. All damage, injury or loss to any property caused, directly or indirectly, in whole or in part, by Contractor, and/or subcontractor, or anyone employed by them shall be remedied by Contractor at Contractor's own expense. Contractor's duties continue until such time as all the work is completed and Project Manager has issued a notice in accordance with paragraph 14.9 that work is acceptable.

6.12.3 Contractor shall designate a responsible member of their organization, at the site, satisfactory to the Project Manager, whose duty shall be the prevention of accidents. This person shall be Contractor's superintendent unless otherwise designated in writing by Contractor to Project Manager.

#### 6.14 Cleaning:

6.14.1 Contractor shall keep the premises free from accumulations of waste materials, rubbish and other debris resulting from the work, and at the completion of the work they shall remove all waste materials, rubbish and debris from and about the premises, as well as all tools, construction equipment and machinery, and surplus materials. They shall leave the site clean and ready for occupancy by Property Owner. Contractor shall restore to original condition those portions of the site not designated for alteration by the Contract Documents.

#### 6.15 Indemnification:

6.15.1 Contractor shall indemnify and hold harmless to the fullest extent permitted by law, the BCRCD Project Manager and their elected officials, officers, consultants, agents and employees, from and against all claims, damages, losses and expenses, including attorneys', accountants', consultants', and experts' fees and expenses, arising out of or resulting from the performance of the work attributable to bodily injury, sickness or death, or to injury to or destruction of tangible property, including the loss of use resulting therefrom, and caused in

whole or in part by any negligent or other act or omission of Contractor, any subcontractor, anyone directly or indirectly employed by any of them or anyone for whose acts any of them may be liable, regardless of whether indemnification shall extend to claims, demands, or liability for injuries occurring after completion of the project as well as during the work's progress. Such obligation shall not be construed to negate, abridge or otherwise reduce any other obligation of indemnity which otherwise exists under the Contract Documents or at law as to any party or person described in this paragraph or otherwise.

6.15.2 In any and all claims against BCRCO Project Manager, their elected officials, officers, employees, consultants or agents by an employee of Contractor, any subcontractor, anyone directly or indirectly employed by any of them or anyone for whose acts any of them may be liable, the indemnification obligation under subparagraph 6.15.1 shall not be limited in any way by any limitation on the amount or type of damages, compensation or benefits payable by or for Contractor or any subcontractor under workmen's compensation acts, disability acts or other employee benefit acts.

#### 6.16 Books and Records:

6.16.1 Contractor shall maintain books, records, documents and other evidence pertinent to the work in accordance with generally accepted accounting principles and practices. Such books, records, documents and other evidence shall be maintained for at least three years after the date of completion of the project. Access to the aforementioned books, records, documents and other evidence shall be available to the BCRCO or the Board, or any authorized representative of either, during the course of construction and for at least three years after completion of the project. Suitable facilities shall be provided for said access.

### **ARTICLE 7 - WORK BY OTHERS**

7.1 BCRCO may perform additional work related to the project or it may award other direct contracts. Contractor shall afford the other persons or contractors who are parties to such direct contracts reasonable opportunity for the storage of materials and equipment and the execution of work. Contractor shall properly connect and coordinate their work with the work of others. No claim for time extension will be made by the Contractor due to any alleged problems or difficulties suffered due to work performed by others unless written notice within twenty-four hours of the commencement of said alleged delaying activities is given to the BCRCO.

7.2 If any part of Contractor's work depends, for proper execution or results, upon the work of any other such person or contractor, Contractor shall inspect and promptly report to Project Manager and Engineer in writing any defects or deficiencies in such work that render it unsuitable for such proper execution and results. Contractor's failure to report as such shall constitute an acceptance of the other work as fit and proper for the relationship of their work, except as to defects and deficiencies which may appear in the other work after the execution of Contractor's work.

7.3 Contractor shall do all cutting, fitting, and patching of their work that may be required to make the several parts come together properly and fit to receive or be received by such other work. Contractor shall not endanger any work of others by cutting, excavating or otherwise altering their work, and will only cut or alter their work with the written consent of the BCRCD and of the other contractors whose work will be affected.

7.4 If the performance of additional work by other persons or contractors is not noted in the Contract Documents prior to the execution of the Agreement, written notice thereof shall be given to Contractor prior to starting any such additional work.

## **ARTICLE 8 - BCRCD'S RESPONSIBILITIES**

8.1 Communications: BCRCD will forward all instructions and decisions to Contractor through the Project Manager.

8.2 Right to Stop Work: The BCRCD has the right to stop or suspend work, and to award other work.

8.3 Project Manager:

8.3.1 The BCRCD will designate a Project Manager and assistants to enable it to carry out its responsibilities at the site. The Project Manager is the BCRCD's agent and shall act as directed by and under the supervision of the BCRCD Administrator.

8.3.2 The Project Manager will be the BCRCD's sole authorized representative for the project. All correspondence to Engineer from Contractor will be copied to the Project Manager.

8.4 Disputes Resolution:

8.4.1 A dispute, or claim, or other matter in question arising out of or relating to the Contract Documents which is not disposed of by agreement shall be decided by the Project Manager promptly and in writing as provided in the Contract Documents. The decision of the Project Manager shall be final and conclusive on the Contractor unless, within 5 days from the receipt of such decision, Contractor submits to Project Manager a written claims submission and documentation as defined in paragraph 8.6 below.

8.5 Disputed Work:

8.5.1 Should Contractor object to any decision, order, directive, notice, action, or omission of Project Manager, Contractor may, within 5 days after receipt or occurrence of the same, or before commencing with the disputed work, whichever occurs first, furnish to Project Manager a written notice stating such objections.

8.5.2 Contractor shall furnish to Project Manager, beginning with the first day and at the end of each day detailed hourly records for labor, construction equipment, and services; and itemized records of materials and equipment used that day in performance of the disputed work. Such records shall be of a form approved by Project Manager. Such records shall be signed by Contractor and verified by Project Manager.

8.5.3 Failure by Contractor to furnish such written notice and records specified in 8.5.1 and 8.5.2 shall constitute a waiver of Contractor's right to furnish a claim for the disputed work.

#### 8.6 Claims Submission and Documentation:

8.6.1 Contractor may furnish a claim concerning a matter noticed in accordance with 8.5 to the BCRCD, 641 Entler Ave, Ste. 47, Chico, CA 95928.

8.6.2 Contractor shall furnish 3 certified copies of claim documentation. The claim documentation shall be complete when furnished. The evaluation of the Contractor's claim will be based on BCRCD's records and the Contractor's furnished claim documentation.

8.6.3 Claim documentation shall conform to generally accepted auditing standards and shall be in the following format: 1. General Introduction 2. General Background 3. Issues a) Index of Issues b) For each Issue 1) Background 2) Chronology 3) Contractor's Position (reason for BCRCD potential liability) 4) Supporting Documentation of Merit 5) Supporting Documentation of Damages 4. Critical Path Method Schedules, As-Planned and As-Built 5. Productivity Exhibits 6. Summary of Issues and Damages

8.6.4 Supporting documentation of merit for each issue shall be cited by reference, photocopied, or explained. Supporting documentation may include, but not be limited to general conditions, technical specifications, drawings, correspondence, conference notes, shop drawing, survey books, inspection reports, delivery schedules, test reports, daily reports, subcontracts, fragmentary critical path method schedules, photographs, technical reports, requests for information, field instructions, and other related records.

8.6.5 Supporting documentation of damages for each issue shall be cited, photocopied, or explained. Supporting documentation may include but not be limited to certified detailed labor, materials, equipment, and construction equipment and services costs; purchase orders; invoices; project as-planned and as-built costs; subcontractor payment releases; quantity reports; other related records; general ledger and any other accounting materials.

8.6.6 Each copy of claim documentation shall include the following certification: 1. I certify under penalty of perjury, according to the laws of the State of California that this claim is made in good faith, that the supporting documentation is accurate and complete to the best of my knowledge and belief; and that the amount requested accurately reflects the contract adjustments for which

BCRCD is responsible. 2. Certification shall be signed in the same manner as the proposal was signed.

8.6.7 Should Contractor be unable to support any part of the claim and it is determined that such inability is attributable to falsity of such certification or misrepresentation of fact or fraud on the part of Contractor, Contractor shall be liable to BCRCD for three times the amount of damages which the BCRCD sustains, plus the cost of civil action and may be liable to the BCRCD for a civil penalty of up to ten thousand dollars for each false claim.

#### 8.7 Decisions on Claims:

8.7.1 Claims of Contractor arising under and by virtue of the contract will be decided by the BCRCD of Butte County Board of Directors, BCRCD Manager, BCRCD Counsel, the Engineer and the Project Manager all or in part who will furnish the decisions to Contractor in writing.

#### 8.8 Release of Undecided Claims:

8.8.1 Undecided claims furnished to the BCRCD Board of Directors before execution of the final release of claims provided in 8.6 and not excepted therefrom shall be deemed released by Contractor upon execution of such release and will not be further considered by the BCRCD.

#### 8.9 Exhaustion:

8.9.1 Contractor must exhaust all remedies and comply with all dispute resolution procedures set forth in paragraph 8.4 prior to filing suit which names the BCRCD Project Manager or any officer, employee, agent or affiliate thereof.

### **ARTICLE 9 - ENGINEER'S STATUS DURING CONSTRUCTION**

9.1 The BCRCD project manager(s) and Feather River Ranger District staff will be responsible for monitoring the progress and quality of the executed work and to determine if the work is proceeding in accordance with the Contract Documents. There is no separate Engineer role on this project.

9.1.2 Project Manager will have access to the work at all times for the observation of the building operations, including the right to accept or reject materials and/or workmanship. The Project Manager and their representatives shall perform their duties in accordance with Section 4-333(a) and 4-341, Title 24, California Code and Regulations.

9.1.3 In cases of emergency the Project Manager may give directions to the Contractor, their authorized representative, or if neither are available, to the superintendent or foreperson in charge of the particular work concerning which directions are given. Such directions will be confirmed in writing by the Project Manager.

### 9.3 Rejecting Defective Work:

9.3.1 Project Manager will have authority to disapprove or reject work which is "defective" (which term includes without limitation work that is unsatisfactory, faulty, does not conform to the requirements of the Contract Documents, does not meet the requirements of any inspection, test or approval referred to in paragraph 13.2, or has been damaged prior to approval of final payment).

## **ARTICLE 10 - CHANGES IN THE WORK:**

10.1 The BCRCDC may at any time or from time to time order additions, deletions or revisions in the general scope of work without invalidating the Contract Documents and without notice to the sureties.

10.2 Changes will be authorized by a Change Order. Upon receipt of a Change Order, Contractor shall immediately proceed with the work involved. All such work shall be executed under the applicable conditions of the Contract Documents. If any Change Order causes an increase or decrease in the contract price or any extension or shortening of the contract time, an adjustment will be made as provided in Articles 11 and 12, on the basis of a claim made by either Contractor or BCRCDC.

10.3 Changes, Omissions, or Additions shall be made only through a standard written order of the Engineer and approved by the BCRCDC. Change Orders will be issued only before or at the time of change, and the expense or responsibility for any change or damage without said order shall rest entirely with the Contractor.

10.4 BCRCDC may order minor changes or alterations in the work not involving extra costs or extension of time, and not inconsistent with the overall intent of the Contract Documents. Such changes may be ordered by a Field Order.

10.5 When necessary, in order to avoid delay to the work, the Project Manager may authorize the Contractor to proceed with the work pending completion of a change order. This prior authorization may be verbal; however, it must be confirmed in writing as soon as possible by the authorizing individual. Whenever work is to proceed on the basis of such prior authorization, the Contractor must be notified in writing to proceed with the work pending approval of the change order. In the case of a change order requested by the Contractor, the BCRCDC must have

positive assurance that Contractor will execute the change order before allowing work to proceed. Preparation and final approval of change orders for work covered under prior authorization must be actively pursued. Prior authorization does not include authority to make payment for the work.

10.6 No claims for adjustment of contract price or time for delays or costs due to material shortage, transportation difficulties, labor shortage, or dewatering, will be paid by BCRCO except as defined in subparagraphs 12.1.2 and 12.1.3.

10.7 Additional work performed by Contractor without authorization of a change order shall be at Contractor's own expense. Contractor shall not be entitled to an increase in the contract price or an extension of the contract time, except in the case of an emergency as provided in subparagraphs 6.1.4 or 9.1.3, for such work performed without a change order.

10.7 The BCRCO may order changes in the work. Notwithstanding any dispute or controversy that may arise in connection with a claim for adjustment of contract price, in the event of such changes Contractor shall proceed with the work promptly and diligently upon written order from Project Manager. The contract price may be changed pursuant to Article 11 without notice to the Surety.

10.8 In the event that there is any dispute between the BCRCO and Contractor with relation to any payment to be made under this contract, whether by reason of change order; progress payment; or otherwise, Contractor shall submit a claim pursuant to Articles 11 and 12 but will not be entitled to walk off the job or stop work in any manner and is under a full obligation to complete each and every term and condition of the contract.

10.9 Dispute resolutions provisions of paragraphs 8.5 and 8.6 are applicable to changes in the work except as in Articles 11 and 12.

## **ARTICLE 11 - CHANGE OF CONTRACT PRICE**

11.1 Contract Price:

11.1.1 The Contract Price constitutes the total amount payable to Contractor for performing the work under the Contract Documents. All duties, responsibilities and obligations assigned to or undertaken by Contractor in respect to work under the Contract Documents shall be at their expense without change of the Contract Price.

11.1.2 If Contractor wishes to make a claim for an increase to the contract price, they shall give Project Manager written notice thereof not later than five (5) days after the occurrence of the event giving rise to such claim. Within ten (10) days thereafter, Contractor shall supply all supporting documents for such claim, including but not limited to time slips for labor and time

slips for equipment. Failure to provide all supporting documents shall constitute a waiver of such claim by Contractor.

11.1.3 The written notice shall set forth the reasons for which the Contractor believes additional compensation is due, the nature of the costs involved and the amount thereof. The notice must be given to the Project Manager prior to Contractor's performing the work-giving rise to the claim for additional compensation.

11.1.4 Differences between the parties arising under and by virtue of the contract shall be brought to the attention of the respective parties at the earliest possible time in order that such matters may be promptly settled. The Contractor hereby agrees that they shall have no right to additional compensation for any claim for which written notice was not filed in strict compliance with this paragraph.

11.2 The cost or credit to the BCRCO resulting from a change in the work, from a prior authorization, or from any claim for an increase or decrease in the contract price shall be determined by the Project Manager in one of the following ways:

11.2.1 By a lump sum properly itemized, and showing direct cost and markup, and supported by such substantiating data as may be required by the Project Manager to permit evaluation; allowable markup shall not in any case exceed the amount set forth below: 1. For work performed by the Contractor's own forces, for changes up to \$2,000, an additional 10% for overhead and 5% for profit may be added; 2. For changes in excess of \$2,000, the sums in excess of \$2,000 are allowed an additional 8% for overhead and 5% for profit; 3. For work performed by subcontractors, the subcontractors' billings shall be limited to the markups as described for the Contractor, except the Contractor may add 10% to the gross amount as set forth by the subcontractor, as their fee for coordinating and implementing such changed work by the subcontractor; 4. Overhead includes, but is not limited to, insurance, supervision, office expense, management, transportation and small tools allowance.

11.2.2 Where the work involved is related to unit prices, by application of unit prices to quantities involved; or

11.2.3 On the basis of force account as provided for in paragraph 11.3 which shall be employed only at the Project Manager's sole discretion, which shall not be an election of the Contractor.

11.2.4 All work undertaken by prior authorization shall be on the basis of force account, until and unless a lump sum is agreed upon.

11.3 Force Account Payment - When extra work is to be paid for on a force account basis, the labor, materials, and equipment used in the performance of such work shall be subject to the approval of the Project Manager and compensation will be determined as follows:

11.3.1 Work Performed by Contractor - The Contractor will be paid the direct costs for labor ,materials and equipment used in performing the work determined as hereinafter provided in Sections "Labor," "Materials" and "Equipment Rental," except where agreement has been reached to pay in accordance with Section "Work Performed by Special Forces or Other Special Services."

11.3.2 To the total direct costs computed as provided in Sections "Labor," "Materials," and "Equipment Rental," there will be added a markup as defined in paragraph 11.2.1.

11.3.3 The above markups shall constitute full compensation for all overhead costs which shall be deemed to include all items of expense not specifically designated as cost or equipment rental in Sections "Labor," "Materials," and "Equipment Rental." The total payment made as provided above shall be deemed to be the actual cost of such work and shall constitute full compensation therefore.

11.3.4 When extra work paid for on a force account basis is performed by forces other than the Contractor's organization, the Contractor shall reach agreement with such other forces as to the distribution of the payment made by the BCRCD of such work. No additional payment therefore will be made by the BCRCD by reason of the performance of the work by a subcontractor or other forces.

11.3.4.1 Labor - The Contractor will be paid the cost of labor for the workcrew (including foreperson when authorized by the Project Manager) used in the actual and direct performance of the work. The cost of labor, whether the employer is the Contractor, subcontractor, or other forces, will be the sum of the following:

11.3.4.2 Actual Wages - The actual wages paid shall include any employer payments to or on behalf of the workcrew for health and welfare, pension, vacation, and similar purposes.

11.3.4.3 Labor Surcharge - To the actual wages, as defined in Section 11.4.2 will be added a labor surcharge set forth in the Department of Transportation publication entitled Labor Surcharge and Equipment Rental Rates, which is in effect on the date upon which the work is accomplished and which is part of the contract. Said labor surcharge shall constitute full compensation for all payments imposed by State and Federal laws, specifically worker's compensation, social security, Medicare, Federal unemployment insurance, State unemployment insurance and State training taxes, and for all other payments made to, or on behalf of, the workmen, other than actual wages as defined in Section 11.4.2 and subsistence and travel allowance as specified in Section 11.3.4.4.

11.3.4.4 Subsistence and Travel Allowance - The actual subsistence and travel allowance paid to such workmen.

11.3.4.5 Materials - The BCRCO of Butte County reserves the right to furnish such materials as it deems advisable, and the Contractor shall have no claims for costs and markup on such materials. Only materials furnished by the Contractor and necessarily used in the performance of the work will be paid for. The cost of such materials will be the cost to the purchaser, whether Contractor, subcontractor, or other forces, from the supplier thereof, except as the following:

11.3.4.6 If materials are procured by the purchaser by any method which is not a direct purchase from and a direct billing by the actual supplier to such purchaser, the cost of such materials shall be deemed to be the price paid to the actual supplier as determined by the Project Manager plus the actual costs, if any, incurred in the handling of such materials.

11.3.4.7 If the materials are obtained from a supply or a source owned wholly or in part by the purchaser, the cost of such materials shall not exceed the price paid by the purchaser for similar materials furnished from said source on contract items or the current wholesale price for such materials delivered to the job site, whichever price is lower.

11.3.4.8 If the cost of such materials is, in the opinion of the Project Manager, excessive, then the cost of such materials shall be deemed to be the lowest current wholesale price at which such materials are available in the quantities concerned delivered to the job site, less any discounts as provided in Section 11.4.1.

11.5 The amount of credit to be allowed to BCRCO for any change which results in a net decrease in cost of the work, will be the amount of the actual net decrease as determined by the Project Manager. When both additions and credits are involved in any one change, any Contractor's fee under paragraph 11.3.3 shall be calculated on the basis of the net increase, if any.

11.6 Whenever the cost of any work is to be determined pursuant to paragraph 11.3, Contractor will submit in form prescribed by BCRCO an itemized cost breakdown together with supporting data.

11.7 Disputes, claims and matters in question arising out of or relating to the interpretation of implementation of Article 11 shall be submitted and resolved in accordance with paragraph 8.5.

11.8 Cash Allowances - NOT APPLICABLE

11.9 All parties agree that the following form shall be used for all change orders:

Contract Change Order Form

Contract Change Order Number: \_\_\_\_\_

Date: \_\_\_\_\_ Sheet: \_\_\_\_\_ of \_\_\_\_\_

\_\_\_\_\_. You are hereby directed to make the herein-described changes from the plans and specifications, or do the following described work in accordance with applicable provisions of the Contract Documents. Work described herein shall include furnishing of all materials, equipment, labor and services necessary for its completion. This Change Order constitutes a full accord and satisfaction as to claims for all additional costs and extensions of the contract time relating to the portion of the work described under the term "Item." The execution of this Change Order is a waiver of any rights or claims by the Contractor to any additional compensation for the "Item" work or extensions of the contract time for that work. ITEM: The above changes result in the following adjustments to the Contract Price: Add/Deduct \$ \_\_\_\_\_.

Contract Time is increased / decreased / unchanged \_\_\_\_\_ working days by this Change Order.

I, the undersigned Contractor, have given careful consideration to the change proposed and hereby agree to do the work above specified and will accept as full payment therefore the prices shown above.

Contractor: \_\_\_\_\_ Date: \_\_\_\_\_

Title: \_\_\_\_\_

**RECOMMENDED FOR APPROVAL:**

Project Manager: \_\_\_\_\_ Date: \_\_\_\_\_

Continues on next page

**APPROVED BY:**

District Manager: \_\_\_\_\_ Date: \_\_\_\_\_

Contract Change Order No: \_\_\_\_\_

Project: \_\_\_\_\_

Date: \_\_\_\_\_

The Contract is changed as follows:

CCO#	COR#	Description		Amount
		Requested by: Reason:	ADD	

		Requested by: Reason:	ADD	
		Requested by: Reason:	ADD	
		Total Change Order No: _____	ADD	\$

The Original Contract Sum:	\$
Net Change by previously authorized Change Orders:	\$
The Contract Sum prior to Change Order:	\$
The Contract Sum will be increased in the amount of:	\$
The New Contract Sum including the Change Order will be:	\$
The Contract Time will be extended:	days

End of Contract Change Order Form

## ARTICLE 12 - CHANGE OF THE CONTRACT TIME

### 12.1 Contract Time

12.1.1 The BCRCDC may extend, reduce or adjust the contract time without invalidating the Contract Documents and without notice to the Surety. The contract time may only be changed by a change order. Any claim for an extension in the contract time shall be based on written notice to Project Manager within five (5) days of commencement of the event giving rise to the claim. The notice shall set forth the reasons for the delay, the date of its commencement, the extent of the delay, together with such supporting data as may be required by Project Manager. Change in the contract time shall be incorporated in a change order. Failure to present notice of claim in writing within the stated five days constitutes a waiver for any delay claim.

12.1.2 In the event it is deemed necessary to extend the time for completion of the work, such extensions shall in no way release any guarantee given by the Contractor pursuant to the provisions of the Contract Documents, or the contract let hereunder, nor shall such extension of time relieve or release the Sureties on the bonds executed pursuant to said provision. The Sureties in executing such bonds shall be deemed to have expressly agreed to any such extension of time. The amount of time allowed in any extension of time shall be limited to the period of the delay giving rise to the same as determined by the BCRCDC.

12.1.3 The amount of time extension, if any, to which the Contractor is entitled shall be determined by the Project Manager. No damages of any sort shall be paid to Contractor for delay, disruption, halting, cessation or temporary abandonment, no matter from what cause. Parties acknowledge that on this project, revisions to the Plans for Construction of the Coutelenc Rd MacNab Fencing Project will be needed, and Contractor waives, by entering into the Agreement with BCRCDC, any damages caused by such revision or any other source during the term of this contract. Notwithstanding any dispute which may arise in connection with a claim for adjustment of the contract time, Contractor shall proceed with the work promptly and directly.

### 12.2 Liquidated Damages

12.2.1 The work prescribed by the Contract Documents must be completed within the time set forth in the Agreement, or damage will be sustained by the BCRCDC. Any delay could cause delay to operations of the BCRCDC depriving the BCRCDC of the scheduled beginning of the use of the facility under construction. The parties hereto recognize that, because of the foregoing special circumstances, it is impractical and extremely difficult to fix the actual damages.

12.2.2 Accordingly, the parties hereto agree, by execution of the Agreement, the Contractor acknowledges that they understand, have ascertained, and agrees that they shall pay to the BCRCDC, as liquidated damages, and not as a penalty or forfeiture, the amounts herein set forth

for the failure of the Contractor to substantially complete the entire work within the time specified.

12.2.3 Time is therefore of the essence in these Contract Documents and it is imperative that the work included in these Contract Documents be substantially completed within the specified time.

12.2.4 Since it is impossible or extremely impractical, presently, to determine the actual amount of damages which the BCRCO will sustain by reason of such delay, it is, therefore, agreed that the Contractor will pay to the BCRCO liquidated damages in the amount as set forth in subparagraph 12.2.6, for each and every calendar day beyond the time set forth in the Agreement, as adjusted, until the time of completion as determined in paragraph 14.5. The Contractor agrees to promptly pay such liquidated damages as are herein provided. In case the same are not paid as such, Contractor agrees that the BCRCO may deduct the amount thereof from any money due or that may become due the Contractor under the contract.

12.2.5 The parties have endeavored to estimate the actual damages likely to be suffered by the BCRCO in the event of a delay in completion beyond the time set forth in the Agreement, and agree that the amount is a reasonable estimate of the BCRCO's actual damages and are just and reasonable sums under the circumstances presently existing.

12.2.6 It is agreed that the amount of liquidated damages to be paid by the Contractor to the BCRCO for failure to complete the entire work specified by the Contract Completion Date or to meet any deadline set forth in the Agreement for the completion of specified work (as extended, if applicable) is two hundred fifty dollars and no/cents (\$250.00) for each calendar day, continuing after the Substantial Completion Date, as indicated in the Agreement, to the date of actual substantial completion, or until the time of completion of the work necessary to meet such a deadline, as the case may be.

12.2.7 In the event the Contractor shall become liable for liquidated damages under this Section, the BCRCO in addition to all other remedies provided by law, shall have the right to require the Project Manager to withhold any and all retained percentages of payments, subject to the requirements of Sections 4590 and 14402.5 of the California Government Code, which would otherwise be or become due the Contractor until the liability of the Contractor under this Section has been finally determined. The BCRCO shall have the right to use and apply such retained percentages, in whole or in part, to reimburse the BCRCO for all liquidated damages due or to become due to the BCRCO. Any remaining balance of such retained percentages shall be paid to the Contractor only after discharge in full of all liability incurred by the Contractor under this Section or otherwise. If the retained percentage is not sufficient to discharge all such liabilities of the Contractor, the Contractor shall continue to remain liable to the BCRCO until all such liabilities are satisfied in full.

12.2.8 Such amount will be in each case the actual cash value agreed upon as the loss to the BCRCDC resulting from the Contractor's default.

12.2.9 Disputes, claims and matters in question arising out of or relating to the interpretation or implementation of Article 12 shall be submitted and resolved in accordance with paragraph 8.4.

### **ARTICLE 13 - WARRANTY AND GUARANTEE; TEST AND INSPECTIONS; CORRECTION, REMOVAL OR ACCEPTANCE OF DEFECTIVE WORK**

#### 13.1 Warranty and Guarantee

13.1.2 Contractor warrants and guarantees to the BCRCDC that all materials and equipment will be unless otherwise specified, all work will be of good quality, free from faults or defects, in accordance with the requirements of the Contract Documents and of any inspections, tests or approvals required, such as in Paragraph 14.6.1.

13.2. All unsatisfactory work, all faulty or defective work, and all work not conforming to the requirements of the Contract Documents at the time of acceptance thereof or of such inspections, tests or approvals shall be considered defective. All defective work, whether or not in place, may be rejected, corrected or accepted as the BCRCDC may direct.

#### 13.2 Tests and Inspections

13.2.1 If laws, ordinances, rules, regulations or orders of any public authority having jurisdiction require any work to be specifically inspected, tested or approved by some public body, Contractor shall assume full responsibility therefore, pay all costs in connection therewith, and furnish the Project Manager with the required certificates of inspection, testing or approval. All other inspections, tests and approvals required by the Contract Documents shall be performed by the Engineer, Project Manager or BCRCDC and the costs be paid by BCRCDC unless otherwise specified.

13.2.2 Contractor shall give Project Manager timely notice of readiness of the work for all inspections, tests or approvals. If any such work required so to be inspected, tested or approved is covered before such inspections, tests, or approvals are made, without written approval of the Project Manager, it must, if requested by the Project Manager, be uncovered for observation, and such uncovering and replacement shall be at Contractor's expense.

13.2.3 Neither observations by Project Manager nor inspections, tests or approvals shall relieve Contractor from their obligations to perform the work in accordance with the requirements of the Contract Documents.

13.2.4 Any defective work, which may be discovered before final acceptance of the work, shall be corrected immediately by the Contractor, and any unsatisfactory materials shall be rejected,

notwithstanding that they may have been overlooked by an inspector. The inspection of the work shall not relieve the Contractor of any of their obligations to perform satisfactory work as herein prescribed.

13.2.5 Failure or neglect on the part of the BCRCDC or any of its authorized agents to condemn or reject bad or inferior work or materials shall not be construed to imply an acceptance of such work or materials if it becomes evident at any time prior to final acceptance of the work; neither shall it be construed as barring the BCRCDC at any subsequent time from recovery of damages or of such a sum of money as may be needed to build all portions of the work in which fraud was practiced or improper materials used whenever found.

### 13.3 Access to Work

13.3.1 The BCRCDC and its representatives will at all times have access to the work. Contractor shall provide proper and safe facilities for such access and observation of the work and also for any inspection or testing thereof by others.

### 13.5 BCRCDC May Stop the Work

13.5.1 If the work is defective, or Contractor fails to supply sufficient skilled workcrew or suitable materials or equipment, or if Contractor fails to make prompt payments to subcontractors or for labor, materials or equipment, BCRCDC may order Contractor to stop the work, or any portion thereof, until the cause for such order has been eliminated. This right of BCRCDC to stop the work shall not give rise to any duty on the part of BCRCDC to exercise this right for the benefit of Contractor or any other party.

### 13.6 Correction or Removal of Defective Work

13.6.1 The Project Manager will require the Contractor, prior to approval of lump sum payment, without cost to BCRCDC and as specified by Project Manager, to either correct any defective work, whether or not fabricated, installed or completed, or, if the work has been rejected by Project Manager or Engineer, remove it from the site and replace it with non-defective work. If Contractor does not correct such defective work or remove and replace such rejected work within a reasonable time, all as specified in a written notice from Project Manager, BCRCDC may have the deficiency corrected or the rejected work removed and replaced by other persons. All direct or indirect costs of such correction or removal and replacement, including compensation for additional professional services, shall be paid by Contractor. Contractor shall also bear the expenses of making good all work of others destroyed or damaged by their correction, removal, or replacement of their defective work.

13.6.2 The Contractor shall remove from the site within 48 hours, when so directed by the Project Manager, any materials which are not in conformance with the Contract Documents.

### 13.7 One Year Correction Period

13.7.1 If, after the approval of final payment and prior to the expiration of one year after the date of Notice of Completion or such longer periods of time as may be prescribed by law or by the terms of any applicable special guarantee required by the Contract Documents, any work is found to be defective, Contractor shall promptly, without cost to BCRCD and in accordance with BCRCDs written instructions, either correct such defective work, or, if it has been rejected by BCRCD, remove it from the site and replace it with non-defective work. If Contractor does not promptly comply with the terms of such instructions, BCRCD may have the defective work corrected or the rejected work removed and replaced by other persons and all direct and indirect costs of such removal and replacement, including compensation for additional professional services, shall be paid by Contractor. The requirements of this paragraph shall be cumulative with such other indemnification, warranties and guarantees as provided by the Contract Documents, at law and in equity, and shall not be deemed a limitation of any sort on the rights and remedies of the BCRCD against the Contractor

13.7.1.1 The warranties, extended warranties and guarantees in these General Conditions and in the Specification shall be cumulative with such other indemnification, warranties and guarantees as provided by the Contract Documents, or at law or in equity, and shall be deemed a limitation of any sort on the rights and remedies of the BCRCD against the Contractor.

### 13.8 Acceptance of Defective Work

13.8.1 If, instead of requiring correction or removal and replacement of defective work, BCRCD prefers to accept it, it may do so. In such case, if acceptance occurs prior to approval of final payment, a change order shall be issued incorporating the necessary revisions in the Contract Documents, including appropriate reduction in the contract price; or, if the acceptance occurs after approval of final payment, an appropriate amount shall be paid by Contractor to BCRCD.

### 13.9 Work Neglected by Contractor

13.9.1 If Contractor fails to prosecute the work in accordance with the Contract Documents, including any requirements of the construction schedule, BCRCD may give Contractor written notice. Contractor shall respond to BCRCD within 24 hours' receipt of said notice, and conform to said notice within 7 days. BCRCD may, without prejudice to any other remedy it may have, make good the deficiencies, and the cost thereof (including compensation for additional professional services) shall be charged against Contractor. If the payments then or thereafter due Contractor are not sufficient to cover such amount, Contractor shall pay the difference to BCRCD.

## **ARTICLE 14 - PAYMENTS AND COMPLETION**

### 14.1 Schedules:

14.1.1 Work Schedule and activity cost data developed in connection therewith are described in the General Requirements. No progress payment will be made until after the Schedule has been updated as of the date of application. The activity cost data will be incorporated into the form of Application for Payment furnished by the BCRCD.

### 14.2 Application for Payment:

14.2.1 Once work is complete Contractor shall submit to Project Manager for review an Application for Payment filled out and signed by Contractor covering the work completed as of the date of the application and accompanied by such data, vouchers and schedules as may reasonably be required. No payment shall be made for any work or material not specifically incorporated in the project, except equipment purchased by Contractor, delivered to and stored in a bonded warehouse acceptable to the BCRCD of Butte County.

14.2.2 Contractor will not be paid for application of payment until work quality is evaluated and approved by the Project Manager and Property Owner.

### 14.3 Contractor's Warranty of Title:

14.3.1 Contractor warrants and guarantees that title to all work, materials and equipment covered by any Application for Payment, whether incorporated in the project or not, will pass to BCRCD at the time of payment, free and clear of all liens, claims, security interests and encumbrances (hereinafter in these General Conditions referred to as "liens"). The BCRCD may, at any time, require the Contractor to post, at Contractor's expense, a lien release bond as to any lien filed against the project.

### 14.4 Approval of Payments:

14.4.1 Payment of invoice will be made only after receipt of a complete, adequately supported, properly documented and accurately addressed invoice. Failure to use the address exactly as provided above may result in return of the invoice or payment request to the Contractor. All invoices must be approved by the BCRCD Project Manager. Payment shall be deemed complete upon deposit of the payment.

- Invoices must be submitted within 10 days following performance of work.
- Payments shall be made by BCRCD to Contractor within thirty (30) calendar days after BCRCD's receipt of payment from funding agency. Funds appropriated for this agreement are unavailable until BCRCD has submitted Contractor's invoice to funding agency and has received payment.

14.4.1.1 The invoice shall contain the following information:

1. The word "INVOICE" shall appear in a prominent location at the top of page(s);
2. Printed name of the Contractor;
3. Business address of the Contractor, including P.O. Box or street address, City, State, and Zip Code;
4. The date of the invoice;
5. The project name; and
6. An itemized account of the work for which the BCRCD is being billed by task;
7. The time period covered by the invoice, i.e., the term "from" and "to";
8. A brief description of the work performed;
9. The amount due by task. Other costs and charges shall be itemized at full cost supported by complete invoicing and other documentation.
10. The total amount due; this should be in a prominent location in the lower right-hand portion of the last page and clearly distinguished from other figures or computations appearing on the invoice; the total amount due shall include all costs incurred by the Contractor under the terms of this Agreement; and
11. Signature of Contractor

14.4.5 It is mutually understood and agreed that when under any provision of this contract the BCRCD shall charge any sum of money against the Contractor, the amount of such charge shall be deducted and retained by the BCRCD from the amount of the next succeeding progress estimate, or from any other moneys due or that may become due the Contractor on account of the contract. If on completion or termination of the contract such moneys due the Contractor are found insufficient to cover the BCRCD's charges against them, the BCRCD shall have the right to recover the balance from the Contractor or their sureties.

14.4.6 The BCRCD may withhold up to 125% of the estimated cost of remedial work from payments otherwise due the Contractor, if in the judgment of the Project Manager or Engineer the Contractor has failed to make satisfactory progress on the completion of remedial work, or is otherwise in violation of any requirement, duty, obligation or covenant contained in the Contract Documents. Such withholding is supplementary to the retention amount required by these Contract Documents.

14.4.7 BCRCD may refuse to approve the payment because of subsequently discovered evidence, change in circumstances or the results of subsequent inspections or tests, and may nullify any such payments previously approved to such extent as may be necessary in their opinion to protect BCRCD from loss, because:

14.4.7.1 the work is defective, or completed work has been damaged requiring correction or replacement;

14.4.7.2 claims or liens have been filed, or there is reasonable cause to believe such may be filed;

14.4.7.3 the contract price has been reduced because of modification;

14.4.7.4 BCRCDC has been required to correct defective work or complete the work;

14.4.7.5 of unsatisfactory prosecution of the work including failure to furnish acceptable submittals; or

14.4.7.6 the Contractor has failed to comply with the Contract Documents, direction of BCRCDC or with the requirements of the law.

#### 14.5 Notice of Completion:

14.5.1 Contractor will certify in writing to BCRCDC, prior to final payment, that the entire project is substantially complete and request that BCRCDC issue a Notice of Completion. Within a reasonable time thereafter, Project Manager, Contractor, and Engineer shall make a review of completeness. If Project Manager does not consider the project substantially complete, Project Manager will notify Contractor in writing giving their reasons. If Project Manager considers the project substantially complete, Project Manager will prepare a provisional Notice of Completion which shall fix the tentative date of Substantial Completion and the responsibilities for maintenance and utilities. There shall be attached to the provisional certificate a list of items to be completed or corrected before final payment, and the provisional certificate shall fix the time within which such items shall be completed or corrected, said time to be within the contract time.

14.5.2 Contractor shall have seven (7) days after receipt of the provisional certificate during which they may make written objection to Project Manager as to any provisions of the provisional certificate or attached list. If, after considering such objection, Project Manager concludes that the project is not substantially complete, Project Manager will within seven days after submission of the objection notify Contractor thereof in writing stating the reasons. Upon Contractor's completion of the items listed on the provisional certificate, and upon satisfaction of the terms and conditions of the provisional certificate, the Project Manager shall issue a final Notice of Completion, which shall fix date as may be necessary or appropriate. Project Manager's determination of the date of Substantial Completion and other items under this paragraph shall be final and conclusive on Contractor.

14.5.3 Project Manager shall have the right to exclude Contractor from the project site after the date of Substantial Completion, but Project Manager shall allow Contractor reasonable access to complete punch list items or perform correction and warranty work.

#### 14.6 Partial Utilization:

14.6.1 Prior to final payment, Project Manager may request Contractor in writing to permit BCRCDC to use a specified part of the project which it believes it may use without significant interference with construction of the other parts of the project. If Contractor agrees, it will certify to Project Manager that said part of the project is substantially complete and request Project Manager to issue a certificate of Substantial Completion for that part of the project. Within a reasonable time thereafter Project Manager, Contractor and Engineer shall make an inspection of that part of the project to determine its status of completion. If Project Manager determines that such part is substantially complete, Project Manager shall issue a Certificate of Substantial Completion. If Project Manager does not consider that it is substantially complete, Project Manager will notify Contractor thereof in writing, giving its reasons.

14.6.2 Partial utilization shall not limit any warranty or guarantee by the Contractor, nor shall it constitute a waiver of any right of the BCRCDC, its successors or assigns.

#### 14.7 Final Inspection:

14.7.1 The Contractor shall give written notice that the project is complete. Project Manager and Property Owner will make a final review of completeness, and will notify Contractor in writing of all particulars in which this review reveals that the work is incomplete or defective. Contractor shall immediately take such measures as are necessary to remedy such deficiencies.

#### 14.8 Final Application for Payment:

14.8.1 Contractor shall complete all such corrections to the satisfaction of the Project Manager and deliver all maintenance and operating instructions, schedules, guarantees, bonds, certificates of inspection and other documents required by the Contract Documents or by the Project Manager. Contractor may then make application for final payment following the procedure for progress payments. The final Application for Payment shall be accompanied by such data as the Project Manager may reasonably require, together with complete releases - waivers of liens in a form satisfactory to the Project Manager. Contractor shall also be required to furnish receipts or releases in full; and affidavit that the releases and receipts include all labor, all payrolls, material and equipment for which a lien could be filed, and that all payrolls, material and equipment bills, and other indebtedness connected with the work for which BCRCDC or property might in any way be responsible, have been paid or otherwise satisfied; and consent of the Surety to final payment. If any subcontractor, material man, fabricator or supplier fails to furnish a release or receipt in full, Contractor may be required at Project Manager's sole discretion to furnish a bond or other collateral satisfactory to Project Manager to indemnify BCRCDC against any lien, stop notice, or any other loss or liability. This payment is made pursuant to paragraph 14.11.

#### 14.9 Approval of Final Payment:

14.9.1 If, on the basis of observation and review of the work during construction, final inspection and review of the final Application for Payment, as required by the Contract Documents, Project Manager is satisfied that the work has been fully and satisfactorily completed and that Contractor has fulfilled all their obligations under the Contract Documents, Project Manager will file a Notice of Completion and, within fifteen (15) days after receipt of the final Application for Payment, approved by Project Manager, indicate in writing its approval for payment.

14.9.2 If, on the basis of observation and review of the work during construction, final inspection and review of the final Application for Payment, as required by the Contract Documents, Project Manager is not satisfied that the work has been fully and satisfactorily completed, and that Contractor has not fulfilled all their obligations under the Contract Documents, Project Manager will, within fifteen (15) days after receipt of the final Application for Payment, indicate in writing their disapproval for payment. Thereupon Project Manager will give written notice to Contractor indicating in writing the reasons for refusing to approve final payment, in which case Contractor shall make the necessary corrections and resubmit the Application.

14.9.3 BCRCD shall make payment, including retention, to Contractor, pursuant to an approved final application for Payment, within 15 days of its approval, or on the 30th day following the recording of the Notice of Completion, whichever date is later. The approval and payment procedures described in paragraphs 14.10, 14.11, and 11.4 shall apply to this paragraph.

14.9.4 The Contractor and each assignee under any assignment in effect at the time of final payment shall, if required by the Project Manager, execute and deliver at the time of final payment and as a condition precedent to final payment, a release in form and substance satisfactory to and containing such exemptions as may be found appropriate by the BCRCD, discharging the BCRCD, Project Manager, and their elected officials, officers, agents, and employees of and from all liabilities, obligations and claims arising under this contract.

#### 14.10 Contractor's Continuing Obligation:

14.10.1 Contractor's obligation to perform the work and complete the project in accordance with the Contract Documents shall be absolute. Neither approval of any progress or final payment by BCRCD, nor the issuance of a Notice of Completion, nor any payment by BCRCD to Contractor under the Contract Documents, nor any use or occupancy of the project by BCRCD shall constitute an acceptance of work not in accordance with the Contract Documents.

#### 14.11 Waiver of Claims:

14.11.1 The making and acceptance of each progress payment and of final payment shall constitute a waiver of all prior claims by Contractor against BCRCD which have not been brought to the notice of the BCRCD as provided in the Contract Documents.

14.11.2 If any claim or lien or stop-notice or any other demand for payment or security therefore, including claims or demands upon the performance and payment bond sureties, is made or filed with or against BCRCD, the project or the premises by any person claiming that Contractor or any subcontractor or other person under it has failed to perform its contractual obligations or to make payment for any labor, services, materials equipment, taxes or other items or obligations furnished or incurred for or in connection with the work, or if at any time there shall be evidence of such non-performance or non-payment or of any claim or lien or stop-notice or other demand for which, if established, BCRCD might become liable and which is chargeable to Contractor; or if Contractor or any subcontractor or other person under it causes damage to the work or to any other work on the project; or if the Contractor fails to perform or is otherwise in default under any of the terms or provisions of the Contract Documents, the Project Manager shall have the right to retain from any payment then due or thereafter to become due an amount which in their sole discretion they deem sufficient to:

14.11.2.1 satisfy, discharge and defend against any such claim or lien or stop-notice or other demand, or any action which may be brought or judgment which may be recovered thereon;

14.11.2.2 make good any such non-payment, nonperformance, damage, failure or default; and

14.11.2.3 compensate BCRCD for and indemnify it against any and all losses, liability, damages, costs and expenses (including attorneys', accountants', consultants' and experts' fees and costs) which may be sustained or incurred in connection therewith.

14.11.3 BCRCD shall have the right to apply and charge against Contractor as much of the amount retained as may be required for the foregoing purposes. If the amount retained is insufficient therefore, Contractor shall be liable for the difference and upon written demand immediately pay the same to the BCRCD. The provisions of this paragraph are in addition to such other rights and entitlements as the BCRCD may enjoy against Contractor as elsewhere provided in the Contract Documents, and at law and in equity.

14.11.4 Should any subcontractor, material person, supplier or other such person file or maintain any action on or respecting a claim of mechanic's lien, stop-notice, against payment or performance bond, Contractor shall immediately and at their own expense procure, furnish and record appropriate release bonds in accordance with California Civil Code Sections 3082 through 3267, inclusive, and California Code of Civil Procedure Sections 409 through 409.7, inclusive. Upon Contractor's failure immediately to procure, furnish and record such release bonds, BCRCD shall have right to procure and record such release bonds, and to retain from Contractor's payment the cost thereof. The provisions of this paragraph are in addition to such other rights and entitlements as enjoyed by the BCRCD against Contractor as elsewhere

provided in the Contract Documents, and at law and in equity.

#### 14.12 Price Reduction For Defective Cost or Pricing Data

4.12.1 If the BCRCDC determines that any price (including profit) negotiated in connection with the contract, or any cost reimbursable under this contract, was increased by any significant sums because the Contractor, or any subcontractor furnished incomplete or inaccurate cost or pricing data or data not current, then such price or cost or profit shall be reduced accordingly and the contract shall be modified in writing to reflect such reduction. Failure to agree on a reduction shall be subject to the Disputes Resolution clause of this contract.

14.12.2 Since the contract is subject to reduction under this clause by reason of defective cost or pricing data submitted in connection with certain subcontracts, the Contractor may wish to include a clause in each such subcontract requiring the subcontractor to appropriately indemnify the Contractor. It is also expected that any subcontractor subject to such indemnification will generally require substantially similar indemnification for defective cost or pricing data required to be submitted by their lower tier subcontractors.

#### 14.13 Covenant Against Contingent Fees

14.13.1 The Contractor warrants that no person or selling agency has been employed or retained to solicit or secure this contract upon an agreement or understanding for a commission, percentage, brokerage, or contingent fee, excepting bona fide employees or bona fide established commercial or selling agencies maintained by the Contractor for the purpose of securing business. For breach or violation of this warranty the BCRCDC shall have the right to annul this contract without liability or in its discretion to deduct from the contract price or consideration, or otherwise recover, the full amount of such commission, percentage, brokerage, or contingent fee.

#### 14.14 Gratuities

14.14.1 If the BCRCDC of Butte County finds, after notice and hearing, that the Contractor or any of the Contractor's agents or representatives offered or gave gratuities (in the form of entertainment, gifts, or otherwise) to any official, employee, or agent of the BCRCDC in an attempt to secure a contract or favorable treatment in the awarding, amending, or making any determinations related to the performance of this contract, the BCRCDC may, by written notice to the Contractor, terminate the right of the Contractor to proceed under this contract. The BCRCDC may also pursue other rights and remedies that the law or this contract provides. However, the existence of the facts upon which the BCRCDC makes such findings shall be in issue and may be reviewed in proceedings under the remedy clause of this contract.

14.14.2 In the event this contract is terminated as provided in this clause, the BCRCDC shall be entitled:

(1) to pursue the same remedies against the Contractor as it could pursue in the event of a breach of the contract by the Contractor, and

(2) as a penalty in addition to any other damages to which it may be entitled by law, to exemplary damages in an amount (as determined by the BCRCDD) which shall be not less than 3 nor more than 10 times the costs the Contractor incurs in providing any such gratuities to any such officer or employee.

## **ARTICLE 15 - SUSPENSION OF WORK AND TERMINATION**

### **15.1 BCRCDD May Suspend Work**

15.1.1 The BCRCDD may, at any time and without cause, suspend the work or any portion thereof by notice in writing to Contractor. Contractor shall resume the work when so ordered in writing by BCRCDD.

### **15.2 BCRCDD May Terminate**

15.2.1 The BCRCDD may, without prejudice to any other right or remedy and after giving Contractor and their Surety seven (7) calendar days written notice, terminate the services of Contractor and take possession of the project and of all materials, equipment, tools, construction equipment and machinery thereon owned by Contractor, and finish the work by whatever method it may deem expedient, if the Contractor is adjudged as bankrupt or insolvent, or if they make a general assignment for the benefit of their creditors, or if a trustee or receiver is appointed for Contractor or for any of their property, or if they file a petition to take advantage of any debtor's act, or to reorganize under the bankruptcy or similar laws, or if they fail to supply sufficient skilled workcrew or suitable materials or equipment, or if they fails to make prompt payments to subcontractors or for labor, materials or equipment or if they disregard laws, ordinances, rules, regulations or orders of any public body having jurisdiction, or if they disregard the authority of Project Manager, or if they otherwise violate any provisions of the Contract Documents. In such case Contractor shall not be entitled to receive any further payment until the work is finished. If the unpaid balance of the contract price exceeds the direct and indirect costs of completing the project, including compensation for additional professional services, such excess shall be paid to Contractor. If the costs exceed such balance, Contractor shall pay the difference to BCRCDD.

15.2.2 The termination of the Contractor's services by the BCRCDD shall not affect any rights of the BCRCDD against the Contractor then existing or which thereafter accrue. The retention of any payment of money by BCRCDD due Contractor will not release the Contractor from liability.

15.2.3 The BCRCDD may, after seven (7) calendar days' written notice to Contractor, without cause and without prejudice to any other right or remedy, elect to abandon the project and

terminate the agreement. In such case, Contractor shall be paid for all work then executed, any expense sustained, plus a reasonable profit.

15.2.4 The Contractor may not, under any condition, terminate or stop work because of a dispute, claim or any matter in controversy under the Contract Documents, then under submission, or previously resolved by a final and conclusive decision under paragraph 8.4.

## **ARTICLE 16 - MISCELLANEOUS**

### 16.1 Giving Notice

16.1.1 Notice shall be deemed to have been validly given if delivered in writing to the individual or member of the firm or to an officer of the corporation for whom it is intended, or if delivered at or sent by registered or certified mail, postage prepaid, to the last business address known to the party who gives the notice. Notice shall be effective as of the date of personal service or mailing.

### 16.2 General

16.2.1 All moneys not paid when due hereunder shall bear interest at the rate of 7% annually.

16.2.2 All specifications, drawings, and copies thereof furnished by the Project Manager shall be the property of BCRCO. They shall not be used on another project, and, with the exception of those sets that have been signed in connection with the execution of the Agreement, shall be returned to the BCRCO on request upon completion of the project.

16.2.3 The duties and obligations imposed by these General Conditions and the rights and remedies available hereunder, and, in particular but without limitation, the warranties, guarantees and obligations imposed upon Contractor by the General Conditions and the rights and remedies available to BCRCO and Project Manager thereunder, shall be in addition to, and shall not be construed in any other way as a limitation of, any rights and remedies available to them which are otherwise imposed or available by law, by special guarantee or by other provisions of the Contract Documents.

16.2.4 Should the BCRCO or Contractor suffer injury or damage to their person, property, any of their employees or agents, or others for whose acts they are legally liable because of any error, omission or act, notice of said injury shall be made in writing to the BCRCO within five (5) days of the first observance of such injury or damage.

16.2.5 The Contract Documents shall be governed by the laws of the State of California. In case any provision of the Contract Documents, including without limitation these General Conditions, shall be invalid, illegal or unenforceable, the validity, legality and enforceability of the remaining provisions shall not in any other way be affected or impaired.

16.2.6 No waiver by BCRCDD of any provision of the Contract Documents, including without limitations these General Conditions, shall constitute a waiver of any other provision thereof.

16.2.7 The waiver of any instance is not a waiver in the second instance.

## **ARTICLE 17 - EQUAL OPPORTUNITY**

The Contractor shall maintain policies of employment as follows:

(1) The contractor will not discriminate against any employee or applicant for employment because of race, color, religion, sex, sexual orientation, gender identity, or national origin. The contractor will take affirmative action to ensure that applicants are employed, and that employees are treated during employment without regard to their race, color, religion, sex, sexual orientation, gender identity, or national origin. Such action shall include, but not be limited to the following:

Employment, upgrading, demotion, or transfer; recruitment or recruitment advertising; layoff or termination; rates of pay or other forms of compensation; and selection for training, including apprenticeship. The contractor agrees to post in conspicuous places, available to employees and applicants for employment, notices to be provided setting forth the provisions of this nondiscrimination clause.

(2) The contractor will, in all solicitations or advertisements for employees placed by or on behalf of the contractor, state that all qualified applicants will receive consideration for employment without regard to race, color, religion, sex, sexual orientation, gender identity, or national origin.

(3) The contractor will not discharge or in any other manner discriminate against any employee or applicant for employment because such employee or applicant has inquired about, discussed, or disclosed the compensation of the employee or applicant or another employee or applicant. This provision shall not apply to instances in which an employee who has access to the compensation information of other employees or applicants as a part of such employee's essential job functions discloses the compensation of such other employees or applicants to individuals who do not otherwise have access to such information, unless such disclosure is in response to a formal complaint or charge, in furtherance of an investigation, proceeding, hearing, or action, including an investigation conducted by the employer, or is consistent with the contractor's legal duty to furnish information.

(4) The contractor will send to each labor union or representative of workers with which he has a collective bargaining agreement or other contract or understanding, a notice to be provided advising the said labor union or workers' representatives of the contractor's commitments under this section, and shall post copies of the notice in conspicuous places available to employees and applicants for employment.

(5) The contractor will comply with all provisions of Executive Order 11246 of September 24, 1965, and of the rules, regulations, and relevant orders of the Secretary of Labor.

(6) The contractor will furnish all information and reports required by Executive Order 11246 of September 24, 1965, and by rules, regulations, and orders of the Secretary of Labor, or pursuant thereto, and will permit access to his books, records, and accounts by the administering agency and the Secretary of Labor for purposes of investigation to ascertain compliance with such rules, regulations, and orders.

(7) In the event of the contractor's noncompliance with the nondiscrimination clauses of this contract or with any of the said rules, regulations, or orders, this contract may be canceled, terminated, or suspended in whole or in part and the contractor may be declared ineligible for further Government contracts or federally assisted construction contracts in accordance with procedures authorized in Executive Order 11246 of September 24, 1965, and such other sanctions may be imposed and remedies invoked as provided in Executive Order 11246 of September 24, 1965, or by rule, regulation, or order of the Secretary of Labor, or as otherwise provided by law.

(8) The contractor will include the portion of the sentence immediately preceding paragraph (1) and the provisions of paragraphs (1) through (8) in every subcontract or purchase order unless exempted by rules, regulations, or orders of the Secretary of Labor issued pursuant to section 204 of Executive Order 11246 of September 24, 1965, so that such provisions will be binding upon each subcontractor or vendor. The contractor will take such action with respect to any subcontract or purchase order as the administering agency may direct as a means of enforcing such provisions, including sanctions for noncompliance:

*Provided*, however, that in the event a contractor becomes involved in, or is threatened with, litigation with a subcontractor or vendor as a result of such direction by the administering agency, the contractor may request the United States to enter into such litigation to protect the interests of the United States.

The applicant further agrees that it will be bound by the above equal opportunity clause with respect to its own employment practices when it participates in federally assisted construction work: *Provided*, That if the applicant so participating is a State or local government, the above equal opportunity clause is not applicable to any agency, instrumentality or subdivision of such government which does not participate in work on or under the contract.

The applicant agrees that it will assist and cooperate actively with the administering agency and the Secretary of Labor in obtaining the compliance of contractors and subcontractors with the equal opportunity clause and the rules, regulations, and relevant orders of the Secretary of Labor, that it will furnish the administering agency and the Secretary of Labor such information as they may require for the supervision of such compliance, and that it will otherwise assist the administering agency in the discharge of the agency's primary responsibility for securing compliance.

The applicant further agrees that it will refrain from entering into any contract or contract modification subject to Executive Order 11246 of September 24, 1965, with a contractor debarred from, or who has not demonstrated eligibility for, Government contracts and federally assisted construction contracts pursuant to the Executive Order and will carry out such sanctions and penalties for violation of the equal opportunity clause as may be imposed upon contractors and subcontractors by the administering agency or the Secretary of Labor pursuant to Part II, Subpart D of the Executive Order. In addition, the applicant agrees that if it fails or refuses to comply with these undertakings, the administering agency may take any or all of the following actions: Cancel, terminate, or suspend in whole or in part this grant (contract, loan, insurance, guarantee); refrain from extending any further assistance to the applicant under the program with respect to which the failure or refund occurred until satisfactory assurance of future compliance has been received from such applicant; and refer the case to the Department of Justice for appropriate legal proceedings.

(9) **Subcontracts.** Each nonexempt prime contractor or subcontractor shall include the equal opportunity clause in each of its nonexempt subcontracts.

**END OF SECTION**

## **Appendix A – State Prevailing Wage determination**

GENERAL PREVAILING WAGE DETERMINATION MADE BY THE  
DIRECTOR OF INDUSTRIAL RELATIONS PURSUANT TO CALIFORNIA LABOR CODE  
PART 7, CHAPTER 1, ARTICLE 2, SECTIONS 1770, 1773 AND 1773.1  
FOR COMMERCIAL BUILDING, HIGHWAY, HEAVY CONSTRUCTION AND DREDGING PROJECTS

**Craft: LABORER AND RELATED CLASSIFICATIONS#**

**Determination:**

NC-23-102-1-2026-1

**Issue Date:**

February 22, 2026

**Expiration date of determination:**

June 28, 2026\*\* The rate to be paid for work performed after this date has been determined. If work will extend past this date, the new rate must be paid and should be incorporated in contracts entered into now. Contact the Office of the Director - Research Unit for specific rates at (415) 703-4774.

**Localities:**

All localities within Alameda, Alpine, Amador, Butte, Calaveras, Colusa, Contra Costa, Del Norte, El Dorado, Fresno, Glenn, Humboldt, Kings, Lake, Lassen, Madera, Mariposa, Marin, Mendocino, Merced, Modoc, Monterey, Napa, Nevada, Placer, Plumas, Sacramento, San Benito, San Francisco, San Joaquin, San Mateo, Santa Clara, Santa Cruz, Shasta, Sierra, Siskiyou, Solano, Sonoma, Stanislaus, Sutter, Tehama, Trinity, Tulare, Tuolumne, Yolo, and Yuba Counties.

**AREA 1** - Alameda, Contra Costa, Marin, San Francisco, San Mateo, And Santa Clara Counties.

**AREA 2** - Alpine, Amador, Butte, Calaveras, Colusa, Del Norte, El Dorado, Fresno, Glenn, Humboldt, Kings, Lake, Lassen, Madera, Mariposa, Mendocino, Merced, Modoc, Monterey, Napa, Nevada, Placer, Plumas, Sacramento, San Benito, San Joaquin, Santa Cruz, Shasta, Sierra, Siskiyou, Solano, Sonoma, Stanislaus, Sutter, Tehama, Trinity, Tulare, Tuolumne, Yolo And Yuba Counties.

**WAGE RATES AND TOTAL HOURLY RATES (AREA 1):**

Classification <sup>a</sup> (Journey person)	Basic Hourly Rate <sup>b</sup>	Hours <sup>c</sup>	Total Hourly Rate	Daily/ Saturday Overtime Hourly Rate <sup>d</sup>	Sunday/ Holiday Overtime Hourly Rate
Construction Specialist	\$39.85	8	\$71.01	\$90.94	\$110.86
Group 1; Group 1(B) <sup>e</sup>	\$39.15	8	\$70.31	\$89.89	\$109.46
Group 1 (A)	\$39.37	8	\$70.53	\$90.22	\$109.90
Group 1 (C)	\$39.20	8	\$70.36	\$89.96	\$109.56
Group 1 (E)	\$39.70	8	\$70.86	\$90.71	\$110.56
Group 1 (G)	\$39.35	8	\$70.51	\$90.19	\$109.86
Group 2	\$39.00	8	\$70.16	\$89.66	\$109.16
Group 3; Group 3 (A)	\$38.90	8	\$70.06	\$89.51	\$108.96
Group 4; Group 6 (B)	\$32.59	8	\$63.75	\$80.05	\$96.34
Group 6	\$40.11	8	\$71.27	\$91.33	\$111.38
Group 6 (A)	\$39.61	8	\$70.77	\$90.58	\$110.38
Group 6 (C)	\$39.02	8	\$70.18	\$89.69	\$109.20
Group 6 (D)	\$39.73	8	\$70.89	\$90.76	\$110.62
Group 6 (E)	\$38.75	8	\$69.91	\$89.29	\$108.66
Group 7 – Stage 1 (1 <sup>st</sup> 6 months)	\$27.23	8	\$58.39	\$72.01	\$85.62
Group 7 – Stage 2 (2 <sup>nd</sup> 6 months)	\$31.12	8	\$62.28	\$77.84	\$93.40
Group 7 – Stage 3 (3 <sup>rd</sup> 6 months)	\$35.01	8	\$66.17	\$83.68	\$101.18

**WAGE RATES AND TOTAL HOURLY RATES (AREA 2):**

Classification <sup>a</sup> (Journeyman)	Basic Hourly Rate <sup>b</sup>	Hours <sup>c</sup>	Total Hourly Rate	Daily/ Saturday Overtime Hourly Rate <sup>d</sup>	Sunday/ Holiday Overtime Hourly Rate
Construction Specialist	\$38.85	8	\$70.01	\$89.44	\$108.86
Group 1; Group 1(B) <sup>e</sup>	\$38.15	8	\$69.31	\$88.39	\$107.46
Group 1 (A)	\$38.37	8	\$69.53	\$88.72	\$107.90
Group 1 (C)	\$38.20	8	\$69.36	\$88.46	\$107.56
Group 1 (E)	\$38.70	8	\$69.86	\$89.21	\$108.56
Group 2	\$38.00	8	\$69.16	\$88.16	\$107.16
Group 3; Group 3 (A)	\$37.90	8	\$69.06	\$88.01	\$106.96
Group 4; Group 6 (B)	\$31.59	8	\$62.75	\$78.55	\$94.34
Group 6	\$39.11	8	\$70.27	\$89.83	\$109.38
Group 6 (A)	\$38.61	8	\$69.77	\$89.08	\$108.38
Group 6 (C)	\$38.02	8	\$69.18	\$88.19	\$107.20
Group 6 (D)	\$38.73	8	\$69.89	\$89.26	\$108.62
Group 6 (E)	\$37.75	8	\$68.91	\$87.79	\$106.66
Group 7 – Stage 1 (1 <sup>st</sup> 6 months)	\$26.53	8	\$57.69	\$70.96	\$84.22
Group 7 – Stage 2 (2 <sup>nd</sup> 6 months)	\$30.32	8	\$61.48	\$76.64	\$91.80
Group 7 – Stage 3 (3 <sup>rd</sup> 6 months)	\$34.11	8	\$65.27	\$82.33	\$99.38

**EMPLOYER PAYMENTS:**

Type of Fund	Amount per Hour Worked
Health & Welfare	\$11.10
Pension	\$15.31
Vacation and Holiday	\$3.91
Training	\$0.52
Other	\$0.32

GENERAL PREVAILING WAGE DETERMINATION MADE BY THE  
 DIRECTOR OF INDUSTRIAL RELATIONS PURSUANT TO CALIFORNIA LABOR CODE  
 PART 7, CHAPTER 1, ARTICLE 2, SECTIONS 1770, 1773 AND 1773.1  
 FOR COMMERCIAL BUILDING, HIGHWAY, HEAVY CONSTRUCTION AND DREDGING PROJECTS

**Craft: LABORER AND RELATED CLASSIFICATIONS (Special Single and Second Shift)#**

**Determination:**

NC-23-102-1-2026-1A

**Issue Date:**

February 22, 2026

**Expiration date of determination:**

June 28, 2026\*\* The rate to be paid for work performed after this date has been determined. If work will extend past this date, the new rate must be paid and should be incorporated in contracts entered into now. Contact the Office of the Director - Research Unit for specific rates at (415) 703-4774.

**Localities:**

All localities within Alameda, Alpine, Amador, Butte, Calaveras, Colusa, Contra Costa, Del Norte, El Dorado, Fresno, Glenn, Humboldt, Kings, Lake, Lassen, Madera, Mariposa, Marin, Mendocino, Merced, Modoc, Monterey, Napa, Nevada, Placer, Plumas, Sacramento, San Benito, San Francisco, San Joaquin, San Mateo, Santa Clara, Santa Cruz, Shasta, Sierra, Siskiyou, Solano, Sonoma, Stanislaus, Sutter, Tehama, Trinity, Tulare, Tuolumne, Yolo, and Yuba Counties.

**AREA 1** - Alameda, Contra Costa, Marin, San Francisco, San Mateo, And Santa Clara Counties.

**AREA 2** - Alpine, Amador, Butte, Calaveras, Colusa, Del Norte, El Dorado, Fresno, Glenn, Humboldt, Kings, Lake, Lassen, Madera, Mariposa, Mendocino, Merced, Modoc, Monterey, Napa, Nevada, Placer, Plumas, Sacramento, San Benito, San Joaquin, Santa Cruz, Shasta, Sierra, Siskiyou, Solano, Sonoma, Stanislaus, Sutter, Tehama, Trinity, Tulare, Tuolumne, Yolo And Yuba Counties.

**WAGE RATES AND TOTAL HOURLY RATES (AREA 1):**

Classification <sup>a</sup> (Journeyperson)	Basic Hourly Rate <sup>b</sup>	Hours	Total Hourly Rate	Daily/ Saturday Overtime Hourly Rate <sup>d</sup>	Sunday/ Holiday Overtime Hourly Rate
Construction Specialist	\$42.85	8	\$74.01	\$95.44	\$116.86
Group 1; Group 1(B) <sup>e</sup>	\$42.15	8	\$73.31	\$94.39	\$115.46
Group 1 (A)	\$42.37	8	\$73.53	\$94.72	\$115.90
Group 1 (C)	\$42.20	8	\$73.36	\$94.46	\$115.56
Group 1 (E)	\$42.70	8	\$73.86	\$95.21	\$116.56
Group 1 (G)	\$42.35	8	\$73.51	\$94.69	\$115.86
Group 2	\$42.00	8	\$73.16	\$94.16	\$115.16
Group 3; Group 3 (A)	\$41.90	8	\$73.06	\$94.01	\$114.96
Group 4; Group 6 (B)	\$35.59	8	\$66.75	\$84.55	\$102.34
Group 6	\$43.11	8	\$74.27	\$95.83	\$117.38
Group 6 (A)	\$42.61	8	\$73.77	\$95.08	\$116.38
Group 6 (C)	\$42.02	8	\$73.18	\$94.19	\$115.20
Group 6 (D)	\$42.73	8	\$73.89	\$95.26	\$116.62
Group 6 (E)	\$41.75	8	\$72.91	\$93.79	\$114.66
Group 7 – Stage 1 (1 <sup>st</sup> 6 months)	\$30.23	8	\$61.39	\$76.51	\$91.62
Group 7 – Stage 2 (2 <sup>nd</sup> 6 months)	\$34.12	8	\$65.28	\$82.34	\$99.40
Group 7 – Stage 3 (3 <sup>rd</sup> 6 months)	\$38.01	8	\$69.17	\$88.18	\$107.18

**WAGE RATES AND TOTAL HOURLY RATES (AREA 2):**

Classification <sup>a</sup> (Journeyman) Group	Basic Hourly Rate <sup>b</sup>	Hours	Total Hourly Rate	Daily/ Saturday Overtime Hourly Rate <sup>d</sup>	Sunday/ Holiday Overtime Hourly Rate
Construction Specialist	\$41.85	8	\$73.01	\$93.94	\$114.86
Group 1; Group 1(B) <sup>e</sup>	\$41.15	8	\$72.31	\$92.89	\$113.46
Group 1 (A)	\$41.37	8	\$72.53	\$93.22	\$113.90
Group 1 (C)	\$41.20	8	\$72.36	\$92.96	\$113.56
Group 1 (E)	\$41.70	8	\$72.86	\$93.71	\$114.56
Group 2	\$41.00	8	\$72.16	\$92.66	\$113.16
Group 3; Group 3 (A)	\$40.90	8	\$72.06	\$92.51	\$112.96
Group 4; Group 6 (B)	\$34.59	8	\$65.75	\$83.05	\$100.34
Group 6	\$42.11	8	\$73.27	\$94.33	\$115.38
Group 6 (A)	\$41.61	8	\$72.77	\$93.58	\$114.38
Group 6 (C)	\$41.02	8	\$72.18	\$92.69	\$113.20
Group 6 (D)	\$41.73	8	\$72.89	\$93.76	\$114.62
Group 6 (E)	\$40.75	8	\$71.91	\$92.29	\$112.66
Group 7 – Stage 1 (1 <sup>st</sup> 6 months)	\$29.53	8	\$60.69	\$75.46	\$90.22
Group 7 – Stage 2 (2 <sup>nd</sup> 6 months)	\$33.32	8	\$64.48	\$81.14	\$97.80
Group 7 – Stage 3 (3 <sup>rd</sup> 6 months)	\$37.11	8	\$68.27	\$86.83	\$105.38

**EMPLOYER PAYMENTS:**

Type of Fund	Amount per Hour Worked
Health & Welfare	\$11.10
Pension	\$15.31
Vacation and Holiday	\$3.91
Training	\$0.52
Other	\$0.32

**CLASSIFICATIONS**

**Construction Specialist**

ASPHALT IRONERS AND RAKERS  
CHAINSAW  
CONCRETE DIAMOND CHAINSAW  
LASER BEAM IN CONNECTION WITH  
LABORER'S WORK  
MASONRY AND PLASTER TENDER  
MECHANICAL PIPE LAYER-ALL TYPES  
REGARDLESS OF TYPE OR METHOD OF  
POWER  
CAST IN PLACE MANHOLE FORM SETTERS  
PRESSURE PIPELAYERS  
DAVIS TRENCHER – 300 OR SIMILAR TYPE  
(AND ALL SMALL TRENCHERS)  
STATE LICENSED BLASTERS AS DESIGNATED  
DIAMOND DRILLERS  
DIAMOND CORE DRILLER  
MULTIPLE UNIT DRILLS  
HIGH SCALERS (INCLUDING DRILLING OF  
SAME)  
HYDRAULIC DRILLS  
CERTIFIED WELDER

**GROUP 1** (FOR CONTRA COSTA COUNTY  
ONLY, USE GROUP 1 (G) FOR SOME OF THE  
FOLLOWING CLASSIFICATIONS)

ASPHALT SPREADER BOXES (ALL TYPES)  
BARKO, WACKER AND SIMILAR TYPE  
TAMPERS  
BIOHAZARD CLEANUP WORKER  
BUGGYMOBILE  
CAULKERS, BANDERS, PIPEWRAPPERS,  
CONDUIT LAYERS, PLASTIC PIPE LAYERS  
CERTIFIED ASBESTOS AND MOLD REMOVAL  
WORKER  
CERTIFIED HAZARDOUS WASTE WORKER  
(INCLUDING LEAD ABATEMENT)  
COMPACTORS OF ALL TYPES  
CONCRETE AND MAGNESITE MIXER AND ½  
YARD  
CONCRETE PAN WORK  
CONCRETE SANDERS, CONCRETE SAW  
CRIBBERS AND/OR SHORING  
CUT GRANITE CURB SETTER  
DRI PAK-IT MACHINE  
FALLER, LOGLOADER AND BUCKER  
FORM RAISERS, SLIP FORMS  
GREEN CUTTERS  
HEADERBOARD MEN, HUBSETTERS,  
ALIGNERS BY ANY METHOD  
HIGH PRESSURE BLOW PIPE (1-1/2" OR OVER,

100 LBS. PRESSURE/OVER)  
HYDRO SEEDER AND SIMILAR TYPE  
JACKHAMMER OPERATORS  
JACKING OF PIPE OVER 12 INCHES  
JACKSON AND SIMILAR TYPE COMPACTORS  
KETTLEMEN, POTMEN, AND MEN APPLYING  
ASPHALT, LAY KOLD, CREOSOTE, LIME,  
CAUSTIC AND SIMILAR TYPE MATERIALS  
(APPLYING MEANS APPLYING DIPPING, OR  
HANDLING OF SUCH MATERIALS)  
LAGGING, SHEETING, WHALING, BRACING,  
TRENCH-JACKING, LAGGING HAMMER  
MAGNESITE, EPOXY RESIN, FIBER GLASS AND  
MASTIC WORKERS (WET/DRY)  
NO JOINT PIPE AND STRIPPING OF SAME,  
INCLUDING REPAIR OF VOIDS  
PAVEMENT BREAKERS AND SPADERS,  
INCLUDING TOOL GRINDER  
PERMA CURBS  
PRECAST-MANHOLE SETTERS  
PIPELAYERS (INCLUDING GRADE CHECKING  
IN CONNECTION WITH PIPELAYING)  
PRESSURE PIPE TESTER  
POST HOLE DIGGERS-AIR, GAS, AND  
ELECTRIC POWER BROOM SWEEPERS  
POWER TAMPERS OF ALL TYPES, EXCEPT AS  
SHOWN IN GROUP 2  
RAM SET GUN AND STUD GUN  
RIPRAP-STONEPAVER AND ROCK-SLINGER,  
INCLUDING PLACING OF SACKED  
CONCRETE AND/OR SAND (WET OR DRY)  
AND GABIONS AND SIMILAR TYPE  
ROTARY SCARIFIER OR MULTIPLE HEAD  
CONCRETE CHIPPING SCARIFIER  
ROTO AND DITCH WITCH  
ROTOTILLER  
SAND BLASTERS, POTMEN, GUNMEN, AND  
NOZZLEMEN  
SIGNALING AND RIGGING  
SKILLED WRECKER (REMOVING AND  
SALVAGING OF SASH, WINDOWS,  
DOORS, PLUMBING AND ELECTRIC  
FIXTURES)  
TANK CLEANERS  
TREE CLIMBERS  
TRENCHLESS TECHNOLOGY LABORER- PIPE  
INSTALLATION, BURSTING, RELINING, OR  
SIMILAR  
TRENCHLESS LABORER'S WORK, CAMERA  
CONTROLLER, CCTV  
TURBO BLASTER  
VIBRA-SCREED-BULL FLOAT IN CONNECTION

WITH LABORER'S WORK  
VIBRATORS

**GROUP 1 (A)**

ALL WORK OF LOADING, PLACING AND  
BLASTING OF ALL POWDER &  
EXPLOSIVES OF WHATEVER TYPE,  
REGARDLESS OF METHOD USED FOR  
LOADING AND PLACING  
JOY DRILL MODEL TWM-2A  
GARDENER-DENVER MODEL DH 143 AND  
SIMILAR TYPE DRILLS  
TRACK DRILLERS  
JACK LEG DRILLERS  
WAGON DRILLERS  
MECHANICAL DRILLERS-ALL TYPES  
REGARDLESS OF TYPE OR METHOD  
OF POWER  
BLASTERS AND POWDERMAN  
TREE TOPPER  
BIT GRINDER

**GROUP 1 (B)** -- SEE GROUP 1 RATES

SEWER CLEANERS (ANY WORKMEN WHO  
HANDLE OR COME IN CONTACT WITH RAW  
SEWAGE IN SMALL DIAMETER SEWERS)  
SHALL RECEIVE \$4.00 PER DAY ABOVE  
GROUP 1 WAGE RATES. THOSE WHO WORK  
INSIDE RECENTLY ACTIVE, LARGE  
DIAMETER SEWERS, AND ALL RECENTLY  
ACTIVE SEWER MANHOLES SHALL RECEIVE  
\$5.00 PER DAY ABOVE GROUP 1 WAGE  
RATES.

**GROUP 1 (C)**

BURNING AND WELDING IN CONNECTION  
WITH LABORER'S WORK  
SYNTHETIC THERMOPLASTICS AND SIMILAR  
TYPE WELDING

**GROUP 1 (D)**

SEE FOOTNOTE A ON PAGE 8

**GROUP 1 (E)**

WORK ON AND/OR IN BELL HOLE FOOTINGS  
AND SHAFTS THEREOF, AND WORK ON AND  
IN DEEP FOOTINGS (DEEP FOOTINGS IS A  
HOLE 15 FEET OR MORE IN DEPTH)  
SHAFT IS AN EXCAVATION OVER FIFTEEN (15)  
FEET DEEP OF ANY TYPE

**GROUP 1 (G) APPLIES ONLY TO WORK IN  
CONTRA COSTA COUNTY**

PIPELAYERS (INCLUDING GRADE CHECKING  
IN CONNECTION WITH PIPELAYING),  
CAULKERS, BANDERS, PIPEWRAPPERS,  
CONDUIT LAYERS, PLASTIC PIPE LAYER,  
PRESSURE PIPE TESTER, NO JOINT PIPE  
AND STRIPPING OF SAME, INCLUDING  
REPAIR OF VOIDS, PRECAST MANHOLE  
SETTERS, CAST IN PLACE MANHOLE FORM  
SETTERS IN CONTRA COSTA COUNTY ONLY

**GROUP 1(H)**

SEE FOOTNOTE A ON PAGE 8

**GROUP 2**

ASPHALT SHOVELERS  
CEMENT DUMPERS AND HANDLING DRY  
CEMENT OR GYPSUM  
CHOKE-SETTER AND RIGGER (CLEARING  
WORK)  
CONCRETE BUCKET DUMPER AND  
CHUTEMAN  
CONCRETE CHIPPING AND GRINDING  
CONCRETE LABORERS (WET OR DRY)  
DRILLERS HELPER, CHUCK TENDER, NIPPER  
(ONE CHUCKTENDER ON SINGLE MACHINE  
OPERATION WITH MINIMUM OF ONE  
CHUCKTENDER FOR EACH TWO MACHINES  
ON MULTIPLE MACHINE OPERATION.  
JACKHAMMERS IN NO WAY INVOLVED IN  
THIS ITEM.)  
GUINEA CHASER (STAKEMAN), GROUT CREW  
HIGH PRESSURE NOZZLEMAN, ADDUCTORS  
HYDRAULIC MONITOR (OVER 100 LBS.  
PRESSURE)  
LOADING AND UNLOADING, CARRYING AND  
HANDLING OF ALL RODS AND MATERIALS  
FOR USE IN REINFORCING CONCRETE  
CONSTRUCTION  
PITTSBURGH CHIPPER, AND SIMILAR TYPE  
BRUSH SHREDDERS  
SEMI-SKILLED WRECKER (SALVAGING OF  
OTHER BUILDING MATERIALS) – SEE ALSO  
SKILLED WRECKER (GROUP 1)  
SLOPER  
SINGLEFOOT, HAND HELD, PNEUMATIC  
TAMPER  
ALL PNEUMATIC, AIR, GAS AND ELECTRIC  
TOOLS NOT LISTED IN GROUPS 1 THROUGH  
1 (F)  
JACKING OF PIPE-UNDER 12 INCHES

**GROUP 3**

CONSTRUCTION LABORERS INCLUDING  
BRIDGE LABORERS, GENERAL LABORERS  
AND CLEANUP LABORERS  
DEMOLITION WORKER  
DUMPMAN, LOAD SPOTTER  
FLAGPERSON/PEDESTRIAN MONITOR  
FIRE WATCHER  
FENCE ERECTORS, INCLUDING TEMPORARY  
FENCING  
GUARDRAIL ERECTORS  
GARDENER, HORTICULTURAL AND  
LANDSCAPE LABORERS (SEE GROUP 4, FOR  
LANDSCAPE MAINTENANCE ON NEW  
CONSTRUCTION DURING PLANT  
ESTABLISHMENT PERIOD)  
JETTING  
LIMBERS, BRUSH LOADERS, AND PILERS  
PAVEMENT MARKERS (BUTTON SETTERS)  
PAVERS/INTERLOCKING PAVERS (ALL TYPES)  
AND INTERLOCKING PAVER MACHINES  
MAINTENANCE, REPAIR TRACKMEN AND  
ROAD BEDS  
STREETCAR AND RAILROAD CONSTRUCTION  
TRACK LABORERS  
TEMPORARY AIR AND WATER LINES,  
VICTAULIC OR SIMILAR  
TOOL ROOM ATTENDANT (JOBSITE ONLY)  
TREE REMOVAL  
WHEELBARROW, INCLUDING POWER DRIVEN

**GROUP 3 (A)** -- SEE GROUP 3 RATES  
COMPOSITE CREW PERSON (OPERATION OF  
VEHICLES, WHEN IN CONJUNCTION WITH  
LABORER'S DUTIES)

**GROUP 4**

ALL FINAL CLEANUP OF DEBRIS, GROUNDS  
AND BUILDINGS NEAR THE COMPLETION OF  
THE PROJECT INCLUDING BUT NOT LIMITED  
TO STREET CLEANERS (NOT APPLICABLE  
TO ENGINEERING OR HEAVY HIGHWAY  
PROJECTS)  
CLEANING AND WASHING WINDOWS (NEW  
CONSTRUCTION ONLY), SERVICE  
LANDSCAPE LABORERS (SUCH AS  
GARDENER, HORTICULTURE, MOWING,  
TRIMMING, REPLANTING, WATERING  
DURING PLANT ESTABLISHMENT PERIOD)  
ON NEW CONSTRUCTION  
BRICK CLEANERS (JOB SITE ONLY)  
MATERIAL CLEANERS (JOB SITE ONLY)

**NOTE:** AN ADDITIONAL DETERMINATION FOR  
LANDSCAPE MAINTENANCE WORK AFTER  
THE PLANT ESTABLISHMENT PERIOD OR  
WARRANTY PERIOD IS PUBLISHED IN THE  
NORTHERN CALIFORNIA LANDSCAPE  
MAINTENANCE LABORER DETERMINATION.

**GROUP 6**

STRUCTURAL NOZZLEMAN

**GROUP 6 (A)**

NOZZLEMAN (INCLUDING GUNMAN, POTMAN)  
RODMAN  
GROUNDMAN

**GROUP 6 (B)** -- SEE GROUP 4 RATES GUNITE  
TRAINEE (ONE GUNITE LABORER SHALL BE  
ALLOWED FOR EACH THREE (3)  
JOURNEYMAN (GROUP 6, 6A, 6C, OR  
GENERAL LABORER) ON A CREW. IN THE  
ABSENCE OF THE JOURNEYMAN, THE  
GUNITE TRAINEE RECEIVES THE  
JOURNEYMAN SCALE.).

NOTE: THIS RATIO APPLIES ONLY TO WORK  
ON THE SAME JOB SITE.

**GROUP 6 (C)**

REBOUNDMAN

**GROUP 6 (D)**

ALIGNER OF WIRE WINDING MACHINE IN  
CONNECTION WITH GUNITING OR SHOT  
CRETE

**GROUP 6 (E)**

ALIGNER HELPER OF WIRE WINDING  
MACHINE IN CONNECTION WITH GUNITING  
OR SHOT CRETE

**GROUP 7**

ENTRY LEVEL LANDSCAPE LABORER (RATIO  
FOR ENTRY LEVEL IS ONE IN THREE. AT  
LEAST ONE SECOND PERIOD ENTRY LEVEL  
AND AT LEAST ONE THIRD PERIOD ENTRY  
LEVEL MUST BE EMPLOYED BEFORE  
EMPLOYING ANOTHER FIRST PERIOD  
TRAINEE).

NOTE: THIS RATIO APPLIES ONLY TO WORK  
ON THE SAME JOB SITE

**Recognized holidays:**

Holidays upon which the general prevailing hourly wage rate for Holiday work shall be paid, shall be all holidays in the collective bargaining agreement, applicable to the particular craft, classification, or type of worker employed on the project, which is on file with the Director of Industrial Relations. If the prevailing rate is not based on a collectively bargained rate, the holidays upon which the prevailing rate shall be paid shall be as provided in Section 6700 of the Government Code. You may obtain the holiday provisions for the current determinations on the [Director's General Prevailing Wage Determinations Website](http://www.dir.ca.gov/OPRL/DPreWageDetermination.htm) (<http://www.dir.ca.gov/OPRL/DPreWageDetermination.htm>). Holiday provisions for current or superseded determinations may be obtained by contacting the Office of the Director – Research Unit at (415) 703-4774.

**Travel and/or subsistence payment:**

In accordance with Labor Code Sections 1773.1 and 1773.9, contractors shall make travel and/or subsistence payments to each worker to execute the work. You may obtain the travel and/or subsistence provisions for the current determinations on the [Director's General Prevailing Wage Determinations Website](http://www.dir.ca.gov/OPRL/DPreWageDetermination.htm) (<http://www.dir.ca.gov/OPRL/DPreWageDetermination.htm>). Travel and/or subsistence requirements for current or superseded determinations may be obtained by contacting the Office of the Director – Research Unit at (415) 703-4774.

---

# Indicates an apprenticeable craft. The current apprentice wage rates are available on the [Prevailing Wage Apprentice Determinations Website](http://www.dir.ca.gov/OPRL/PWAppWage/PWAppWageStart.asp) (<http://www.dir.ca.gov/OPRL/PWAppWage/PWAppWageStart.asp>).

<sup>a</sup> GROUP 1(D) - MAINTENANCE OR REPAIR TRACKMEN AND ROAD BEDS AND ALL EMPLOYEES PERFORMING WORK COVERED BY THIS CLASSIFICATION SHALL RECEIVE \$0.25 PER HOUR ABOVE THEIR REGULAR RATE FOR ALL WORK PERFORMED ON UNDERGROUND STRUCTURES NOT SPECIFICALLY COVERED HEREIN. THIS SHALL NOT APPLY TO WORK BELOW GROUND LEVEL IN OPEN CUT. THIS SHALL APPLY TO CUT AND COVER WORK OF SUBWAY CONSTRUCTION AFTER TEMPORARY COVER HAS BEEN PLACED.

GROUP 1(H) - ALL LABORERS WORKING OFF OR WITH OR FROM BOS'N CHAIRS, SWINGING SCAFFOLDS, BELTS RECEIVE \$0.50 PER HOUR ABOVE THEIR APPLICABLE WAGE RATE. THIS SHALL NOT APPLY TO LABORERS ENTITLED TO RECEIVE THE WAGE RATE SET FORTH IN GROUP 1(A).

<sup>b</sup> ZONE PAY AT THREE DOLLARS (\$3.00) PER HOUR, FACTORED AT THE APPLICABLE OVERTIME MULTIPLE, WILL BE ADDED TO THE BASE RATE FOR WORK PERFORMED OUTSIDE THE FREE ZONE DESCRIBED BY THE BOUNDARIES ALONG TOWNSHIP AND RANGE LINES. PLEASE SEE TRAVEL AND SUBSISTENCE PROVISION FOR MAP DESCRIPTION AND EXCEPTIONS.

<sup>c</sup> WHEN THREE SHIFTS ARE EMPLOYED FOR FIVE (5) OR MORE CONSECUTIVE DAYS, SEVEN AND ONE-HALF (7 ½) CONSECUTIVE HOURS (EXCLUSIVE OF MEAL PERIOD), SHALL CONSTITUTE A DAY OF WORK, FOR WHICH EIGHT (8) TIMES THE STRAIGHT TIME HOURLY RATE SHALL BE PAID AT THE NON-SHIFT WAGE RATE FOR THE SECOND SHIFT. THE THIRD SHIFT SHALL BE SEVEN (7) HOURS OF WORK FOR EIGHT (8) HOURS PAY AT THE NON-SHIFT WAGE RATE.

<sup>d</sup> RATE APPLIES TO THE FIRST 4 DAILY OVERTIME HOURS WORKED ON MONDAY THROUGH FRIDAY AND THE FIRST 12 HOURS WORKED ON SATURDAY; ALL OTHER TIME IS PAID AT THE SUNDAY AND HOLIDAY OVERTIME HOURLY RATE. SATURDAYS IN THE SAME WORK WEEK MAY BE WORKED AT STRAIGHT-TIME IF JOB IS SHUT DOWN DURING THE NORMAL WORK WEEK DUE TO INCLEMENT WEATHER, MAJOR MECHANICAL BREAKDOWN OR LACK OF MATERIALS BEYOND THE CONTROL OF THE EMPLOYER.

<sup>e</sup> GROUP 1(B) RECEIVES AN ADDITIONAL AMOUNT EACH DAY. SEE PAGE 6 FOR DETAILS

## Appendix B - SITE MAP



Mercator Projection  
WGS84  
UTM Zone 10S  



## Appendix C: Fire Plan

Summary: The Forest Service uses a fire danger rating system called PALS (Project Activity Levels). There are 5 PALS and each successive level requires additional fire precautions of contractors. At the highest PALS, some activities are only allowed during morning hours or are not allowed at all for the day.

Therefore, in addition to complying with the sections below, **contractors are responsible for knowing the PAL and must call 1-800-847-7766 each day to find out the next day's PAL.** The Coutelenc Rd. MacNab Fencing Project is located on the Feather River Ranger District (FRRD), which is in the West zone of the Plumas National Forest. The applicable RAWS station is "Jarbo Gap." The Forest Service usually updates the hotline at about 5pm to give the rating for the next day.

During fire season when there are fires on the district, in case the hotline is not updated or is unavailable for the day, the PAL reverts to whatever it was the day before.

### C7.2# - SPECIFIED FIRE PRECAUTIONS. (06/2012)

Purchaser or a designated Purchaser's Representative shall certify compliance with specific Timber Sale Contract and California Public Resources Code (CPRC) fire precautionary measures in B7.1 Plans, C7.2# and C7.22#. Certification shall be provided prior to starting operations during Fire Precautionary Period and shall be updated as needed.

Listing of specific fire precautionary measures in the following subsections is not intended to relieve Purchaser in any way from compliance with State fire laws covering fire prevention and suppression equipment applicable to Purchaser's Operations.

Upon request of Forest Service, Purchaser shall permit and assist in periodic testing and inspection of required fire equipment.

The following definitions shall apply to C7.2# and C7.22#:

**Active Landing:** A location Purchaser is skidding logs into, or performing other operations such as delimiting, log manufacturing, and chipping logs. Except for EV and E days, loading logs or stockpiled chips only on a cleared landing does not constitute an Active Landing.

**Hot Saw:** A harvesting system that employs a high-speed (>1100 rpm) rotating felling head (i.e., full rotation lateral tilt head).

**Mechanical Operations:** The process of felling, skidding, chipping, shredding, piling, log processing and/or yarding which requires the use of motorized power which includes, chainsaws, chippers, motorized carriages, masticators, stroke delimiters, skidders etc.

Specific equipment requirements and fire precautionary measures are shown in the following table and in C7.22#:

A. Fire Tools and Equipment Purchaser shall meet applicable parts of Section 4428 of the CPRC.

Unless agreed otherwise, Fire tools kept at each Active Landing shall be sufficient to equip all employees in the felling,

yarding, loading, chipping, and material processing operations associated with each landing. Fire equipment shall include two tractor headlights for each tractor dozer used in Purchaser's Operations. Tractor headlights shall be attachable to each tractor and served by an adequate power source. Fire tools shall be kept in a sealed fire tool box adjacent to the Active Landing and readily accessible in event of fire.

Where cable yarding is used, Purchaser shall provide a size 0 or larger shovel with an overall length of not less than 46 inches and a serviceable 5 gallon backpack pump filled with water or a fire extinguisher bearing a label showing at least a 4-A rating must be within 25 feet of each tail and corner block.

Trucks, tractors/skididers, pickups and other similar mobile equipment shall be equipped with and carry at all times a size 0 or larger shovel with an overall length of not less than 46 inches and a 2-1/2 pound axe or larger with an overall length of not less than 28 inches.

All required fire tools shall be maintained in suitable and serviceable condition for fire fighting purposes.

B. Fire Extinguishers

Purchaser shall equip each internal combustion yarder, fuel truck, and loader with a (4-A:60-B:C) fire extinguisher for oil and grease fires.

Skidders and tractors shall be equipped with a minimum 5-BC fire extinguisher.

Fire extinguishers shall be mounted, readily accessible, properly maintained and fully charged.

Purchaser shall equip all mechanized harvesting machines and log processors with hydraulic systems, powered by an internal combustion engine (e.g. masticator, chipper, feller/buncher, harvester, forwarder, Hot Saw, stroke delimeter, etc), with at least two 4-A:60-B:C fire extinguishers or an acceptable CAFS substitute identified in Section K.

C. Spark Arresters and Mufflers

Except for tractors and other equipment with exhaust-operated turbochargers, Purchaser shall equip each operating tractor and any other internal combustion engine with an approved spark arrester. There shall be no exhaust bypass on any system.

Spark Arresters shall be a model tested and approved under Forest Service Standard 5100-1a as shown in the National Wildfire Coordinating Group Spark Arrester Guide, Volumes 1 and 2, and shall be properly mounted and maintained according to manufacturer's specifications.

Every motor vehicle subject to registration shall at all times be equipped with an adequate exhaust system meeting the requirements of the California Vehicle Code.

D. Power Saws

Each power saw shall be equipped with a spark arrester approved and maintained in effective working order as identified in the

Spark Arrestor Guide in Section C. above and according to applicable parts of CPRC Section 4442 or 4443. An Underwriters Laboratories (UL) approved fire extinguisher containing a minimum 14 ounces of fire retardant shall be kept with each operating saw.

A size 0 or larger shovel with an overall length of not less than 38 inches shall be kept with each gas can, but not more than 300 feet from each power saw when used off cleared landing areas.

E. Fire Supervisor & Fire Patrolperson

Purchaser shall designate in the fire plan required by B7.1 and furnish on Sale Area during operating hours a fire supervisor, named in writing and authorized to act on behalf of Purchaser in fire prevention and suppression matters.

Unless agreed otherwise, Purchaser shall furnish and designate in writing, a Fire Patrolperson each operating day when Project Activity Level C or higher is in effect. When on duty, the Fire Patrolperson is required to patrol the operation for the prevention and detection of fires, to take suppression action where necessary and to notify Forest Service as required under Sections I. Reporting Fires and L. Communications. This Fire Patrol is required on foot, unless otherwise agreed.

By written agreement, one Fire Patrolperson may provide patrol on this and adjacent projects or sales. No Fire Patrolperson shall be required on Specified Road construction jobs except during clearing operations unless otherwise specified.

F. Seasonal Permits

Purchaser shall obtain written permits from Forest Service before allowing welding, warming fires or burning, subject to C7.22# - Emergency Precautions.

G. Clearing of Fuels

Purchaser shall clear away, and keep clear, fuels and logging debris as follows:

Welding equipment and stationary log loaders, yarders and other equipment listed in California State Law:	10 feet slope radius
Tail or corner haulback blocks:	All running blocks on a cable yarding operation shall be located in the center of an area that is cleared to mineral soil at least 15 feet in diameter.
Lines near, between or above blocks:	Sufficient clearing to prevent line from rubbing on snags, down logs and other dead woody material.

H. Smoking

All smoking shall be confined within a car, truck, crew rig or other enclosed cab after 1:00 PM on Ev days and all hours on E days (C7.22#). At other times, any smoking shall be done while sitting in an area at least 3 feet in diameter, cleared of flammable materials. Burning tobacco and matches shall be extinguished before they are properly disposed.

I. Reporting Fires

As soon as feasible, but no later than **15 minutes** after discovery, Purchaser shall notify Forest Service of any fires on Sale Area or along roads used by Purchaser.

J. Tank Truck

Purchaser shall provide a water tank truck or trailer on or in proximity to Sale Area during Purchaser's Operations hereunder during Fire Precautionary Period unless otherwise agreed.

Tank truck or trailer shall contain at least 300 gallons of water and comply with the following requirements:

(1) Pump, which at sea level, can deliver 23 gallons per minute at 175 pounds per square inch measured at the pump outlet. Pumps shall be tested on Sale Area by Forest Service using a 5/16 inch orifice with a one inch in line test kit and shall meet or exceed the pressure values identified in the following table for nearest temperature and elevation:

T E M p	Sea Level		1000 Feet		2000 Feet		3000 Feet		4000 Feet		5000 Feet		6000 Feet		7000 Feet		8000 Feet		9000 Feet		10000 Feet	
	55	179	23	174	23	169	23	165	22	161	22	157	22	153	22	150	21	146	21	142	21	139
70	175	23	171	23	166	22	162	22	158	22	154	22	150	21	147	21	143	21	139	21	136	20
85	171	23	168	23	163	22	159	22	155	22	151	21	147	21	144	21	140	21	136	20	133	20
100	168	23	164	23	159	22	155	22	152	22	148	21	144	21	141	21	137	20	133	20	131	20
	P	G	P	G	P	G	P	G	P	G	P	G	P	G	P	G	P	G	P	G	PSI	G
	S	P	S	P	S	P	S	P	S	P	S	P	S	P	S	P	S	P	S	P		P
	I	M	I	M	I	M	I	M	I	M	I	M	I	M	I	M	I	M	I	M	I	M

The pump outlet shall be equipped with 1-1/2 inch National Standard Fire Hose thread. A bypass or pressure relief valve shall be provided for other than centrifugal pumps.

(2) 300 feet of 3/4-inch inside diameter rubber-covered high-pressure hose mounted on live reel attached to pump with no segments longer than 50 feet, when measured to the extreme ends of the couplings. Hose shall have reusable compression wedge type 1-inch brass or lightweight couplings (aluminum or plastic). One end of hose shall be equipped with a coupling female section and the other end with a coupling male section. The hose shall, with the nozzle closed, be capable of withstanding 200 PSI pump pressure without leaking, distortions,

slipping of couplings, or other failures.

(3) A shut-off combination nozzle that meets the following minimum performance standards when measured at 100 P.S.I. at the nozzle:

	G.P.M.	Horizontal Range
Straight Stream	10	38 feet
Fog Spray	6 - 20	N/A

(4) Sufficient fuel to run pump at least 2 hours and necessary service accessories to facilitate efficient operation of the pump.

(5) When Purchaser is using Hot Saws or Masticators an additional 250 feet of light weight hose, approved by Forest Service, shall be immediately available for use and be capable of connecting to the 300 feet of hose and appurturances in (2) and (3) above.

(6) This equipment and accessories shall be deliverable to a fire in the area of operations and is subject to the requirements for each specific activity level identified in C7.22#.

K. Compressed Air Foam System (CAFS)

A fire suppression system where compressed air is added to water and a foaming agent. By agreement, Purchaser may substitute a CAFS or functional equivalent in lieu of the tank truck, trailer or fire extinguishers, provided it meets or exceeds the following specifications and requirements:

1. Variable foam expansion ratio - 10:1 to 20:1.
2. Units shall be kept fully charged with air; water and foam concentrate as recommended by the manufacturer and have the appropriate tools to service the system.
3. The unit shall contain enough energy to empty tank and clear hose prior to exhausting propellent.
4. The unit shall be capable of being completely recharged within 10 minutes.
5. When used on cable yarding landings, the unit shall be outfitted for immediate attachment to carriage and transported without damage to the unit.

Fire extinguishers required for Hot Saws, Masticators and similar equipment identified in Section B. above may be substituted with a 3 gallon CAFS.

Tank truck, trailer or equivalent may be substituted with a 30 Gallon CAFS with at least 550 feet of one inch hose and an adjustable nozzle with enough water, air and foam concentrate for at least one recharge.

This equipment and accessories shall also be deliverable to a fire in the area of operations and subject to the requirements for each specific activity level identified in C7.22#.

L. Communica-  
tions

Purchaser shall furnish a serviceable communications system such as a telephone, radio-telephone, radio system or satellite phone connecting each operating side within the Sale Area with Purchaser's headquarters, and capable of notifying Forest Service within **15 minutes** of discovery of any fires on the Sale Area or along Purchaser's haul route. When such headquarters is at a location which makes communication to it clearly impractical, Forest Service may agree to a reasonable alternative notification method.

A Citizen's Band (CB) radio is not acceptable communications.

M. Cable  
Yarding Tank  
Unit

When all or part of Included Timber will be harvested by a long span (over 1,500 feet) cable yarding operation, Purchaser shall provide at each active cable yarding landing a tank truck, trailer or acceptable CAFS substitute which can be lifted and transported by the carriage.

The unit shall meet the same requirements as specified for the tank truck, trailer or approved CAFS substitute.

N. Helicopter  
Yarding Fire  
Precautions

Purchaser shall provide and maintain fire equipment as follows:

1. The fire tool box required under this provision shall be equipped for attachment to the helicopter long line so that it may be hauled to needed locations. Such attachment device shall not interfere with access to fire tools. Unless agreed otherwise, the fire tool box shall be located at the Active Landing ready for immediate dispatch.
2. An external helibucket readily attachable to the helicopter, with a capacity of at least 500 gallons, and having a remote control door mechanism adequate for rapid dropping of water. The helibucket shall be located at the helicopter service landing and shall be filled with water ready for immediate dispatch unless otherwise agreed.
3. All aircraft used in conjunction with Purchaser's Operations shall be equipped with an operable radio system capable of meeting Region Five avionics requirements.
4. For protection of fuel servicing operations, fire extinguishers which have the following ratings based on the open hose discharge capacity, i.e., "broken hose," of the aircraft fueling system shall be readily available:
  - a. Where said capacity does not exceed 200 gallons per minute, at least one approved extinguisher having a minimum rating of 20-B;
  - b. Where said capacity is in excess of 200 gallons per minute, but not over 350 gallons per minute, one approved extinguisher having a minimum rating of 80-B;
  - c. Where said capacity is in excess of 350 gallons per minute, two approved extinguishers, each having a minimum rating of 80-B.

5. By agreement, a suitable CAFS may also be used in lieu of the above extinguishers.
6. Extinguishers of over 50 pounds gross weight shall be of wheeled type or be mounted on carts to provide mobility and ease of handling.

C7.22# - EMERGENCY PRECAUTIONS. (06/2012) Purchaser's Operations shall conform to the limitations or requirements in the Project Activity Level (PAL) table below. Unless otherwise agreed in writing, Project Activity Levels applicable to this project shall be the predicted levels for the Fire Danger Rating Area(s), or fire weather station(s) stated in the Sale Area Map legend.

Forest Service, in its sole discretion, may change the predicted activity level if the current fire suppression situation, weather and vegetation conditions warrant an adjustment. If practicable, Forest Service will determine the following day's activity level by 6:00 PM. Purchaser shall obtain the predicted Project Activity Level from the appropriate Ranger District Office before starting work each day.

Forest Service may change the Project Activity Level Table to other values upon revision of the National Fire Danger Rating System. When Purchaser is notified, the revised Project Activity Levels will supersede the levels in the Project Activity Level Table below.

PROJECT ACTIVITY LEVEL (PAL) - C7.22# - EMERGENCY PRECAUTIONS

**PROJECT ACTIVITY LEVEL TABLE**

<b>Level</b>	<b><i>Project Activity Minimum Requirements and Restrictions. Restrictions at each level are cumulative.</i></b>
<b>A</b>	Minimum required by C7.2#.
<b>B</b>	1. Tank truck, trailer, or approved CAFS substitute shall be on or adjacent to the Active Landing.
<b>C</b>	1. When Hot Saws or Masticators are operating, a tank truck, trailer or approved CAFS substitute shall be within ¼ mile of these operations. Effective communications shall exist between the operator and the Active Landing. 2. Immediately after Mechanical Operations cease, Fire Patrol is required for two hours.
<b>D</b>	1. Immediately after Hot Saw or Masticator operations cease, Fire patrol is required for three hours. 2. No Dead Tree felling after 1:00 PM, except recently dead. 3. No Welding or cutting of metal after 1:00 PM, except by special permit.

<p><b>Ev</b></p>	<p>1. The following activities may operate all day:</p> <ul style="list-style-type: none"> <li>a) Loading and hauling logs decked at approved landings.</li> <li>b) Loading and hauling chips stockpiled at approved landings.</li> <li>c) Servicing equipment at approved sites.</li> <li>d) Dust abatement, road maintenance (Chainsaw use prohibited), culvert installation within cleared area, chip sealing, paving, earth moving or rock aggregate stock pile loading and installation (does not include pit or quarry development).</li> <li>e) Chainsaw and log processing operations associated with loading logs or other forest products at approved landings.</li> </ul> <p>2. Hot Saws or Masticators may operate until 1:00 PM; provided that:</p> <ul style="list-style-type: none"> <li>a) A tractor or other equipment with a blade capable of constructing fireline is on or adjacent to the active landing or within ¼ mile of the operating equipment. This piece of equipment shall have effective communication with the Hot Saw or Masticator.</li> <li>b) Any additional restrictions specified by the Forest.</li> </ul> <p>3. All other conventional Mechanical Operations are permitted until 1:00 PM.</p> <p><b>4. Some operations may be permitted after 1:00 PM, on a case-by-case basis, under the terms of a PAL Ev Variance Agreement. Activities for which a Variance may be issued are:</b></p> <ul style="list-style-type: none"> <li>• <b>Rubber Tire Skidding</b></li> <li>• <b>Chipping on Landings</b></li> <li>• <b>Helicopter Yarding</b></li> <li>• <b>Fire Salvage</b></li> </ul> <p>When approved by a Line Officer, a Variance Agreement can be implemented when the criteria specified in the agreement are met and mitigation measures are in place. This approval is good for ten (10) days unless cancelled sooner or extended by the Contracting Officer for an additional ten (10) days. Variance approval can be withdrawn at the sole discretion of Forest Service. Variance approval is contingent on the 7-day fire weather forecast, fuel conditions, site characteristics, current fire situation, state of Purchaser's equipment for prevention and suppression readiness, type of operation and social and community considerations etc. (See attached Project Activity Level Variance Agreement).</p>
<p><b>E</b></p>	<p>The following activities may operate all day:</p> <ul style="list-style-type: none"> <li>1. Loading and hauling logs decked at approved landings.</li> <li>2. Loading and hauling chips stockpiled at approved landings.</li> <li>3. Servicing Equipment at approved sites.</li> <li>4. Dust abatement, road maintenance (chainsaw use prohibited) or loading stock piles and rock aggregate installation (does not include pit or quarry development).</li> <li>5. Chainsaw operation associated with loading at approved landings.</li> </ul> <p>All other activities are prohibited.</p>

--	--

SPECIFICATIONS PURSUANT TO C7.22# - EMERGENCY PRECAUTIONS. (10/2010)

**Region 5 Project Activity Level (PAL) Ev Variance Application/Agreement**

Project Name: \_\_\_\_\_  
 Contract Number: \_\_\_\_\_  
 Purchaser/Contractor Name: \_\_\_\_\_  
 Request #\_\_, for period: \_\_\_\_\_  
 Units/Subdivisions Affected: \_\_\_\_\_

<b>Location of operation:</b>	
Slope	
Aspect	
Elevation	
Fuels on site	
Fuels in surrounding area	
7 Day PAL Outlook	
Short range predictions (Red Flags)	
<i>Fuel Moistures</i>	
Response time of suppression resources	
Potential for ignition	
RAWS location	
<b>Current Fire Situation:</b>	
Draw down information	
National Readiness Level	
<b>Contractual considerations:</b>	
Normal Operating Season	
Frequency of recent contract fires in area	
Type of operation	
Purchaser/Contractors past/current performance & equipment readiness	
Other site specific mitigation or precaution (i.e. Purchaser/Contractors proposals)	
<b>Social &amp; Community Considerations:</b>	
Proximity of high value resources	
Sensitivity of location	

Remarks :

**Ev Proposed Actions**

Rubber Tired Skidding

Chipping on Landings

Helicopter Yarding

Fire Salvage

**Description of Mitigation Measures**

\_\_\_\_\_  
Fire Management Officer Concurrence

\_\_\_\_\_  
Date

\_\_\_\_\_  
Line Officer Approval

\_\_\_\_\_  
Date

I have considered the above request and determined the specified mitigation measures or actions must be implemented to continue operations in Project Activity Level Ev. Unless extended, the approval remains in effect for ten (10) calendar days unless cancelled sooner or extended by the Forest Service for an additional ten (10) days. At the sole discretion of the Forest Service, this variance can be modified and/or cancelled at no cost to the government.

\_\_\_\_\_  
Contracting Officer

\_\_\_\_\_  
Date

\_\_\_\_\_  
Purchaser/Contractor Rep.

\_\_\_\_\_  
Date